

SECTION 1E

ENGINE ELECTRICAL

CAUTION: Disconnect the negative battery cable before removing or installing any electrical unit or when a tool or equipment could easily come in contact with exposed electrical terminals. Disconnecting this cable will help prevent personal injury and damage to the vehicle. The ignition must also be in LOCK unless otherwise noted.

TABLE OF CONTENTS

<p>Specifications 1E-1</p> <p> Starter Specifications 1E-1</p> <p> Generator Specifications 1E-2</p> <p> Battery Specifications 1E-2</p> <p> Fastener Tightening Specifications 1E-2</p> <p>Schematic and Routing Diagrams 1E-3</p> <p> Starting System 1E-3</p> <p> Charging System 1E-4</p> <p>Diagnosis 1E-5</p> <p> No Crank 1E-5</p> <p> Starter Motor Noise 1E-8</p> <p> Battery Load Test 1E-8</p> <p> Generator Output Test 1E-9</p> <p> Generator System Check 1E-9</p> <p>Maintenance and Repair 1E-10</p> <p> On-Vehicle Service 1E-10</p> <p> Generator - 95 Amp 1E-10</p> <p> Starter - PG 150S 1E-13</p> <p> Battery/Battery Tray 1E-14</p>	<p> Unit Repair 1E-17</p> <p> Starter Motor 1E-17</p> <p> Generator 1E-27</p> <p>General Description and System</p> <p> Operation 1E-35</p> <p> Battery 1E-35</p> <p> Ratings 1E-35</p> <p> Reserve Capacity 1E-35</p> <p> Cold Cranking Amperage 1E-35</p> <p> Built-in Hydrometer 1E-35</p> <p> Charging Procedure 1E-35</p> <p> Charging Time Required 1E-36</p> <p> Charging a Completely Discharged Battery (Off the Vehicle) 1E-36</p> <p> Jump Starting Procedure 1E-36</p> <p> Generator 1E-37</p> <p> Charging System 1E-37</p> <p> Starter 1E-37</p> <p> Starting System 1E-37</p>
--	---

SPECIFICATIONS

STARTER SPECIFICATIONS

Application	Description
Starter	
No-Load Test @ 12.2 Volts	40-90 amps
Drive Pinion Speed	3,200-4,800 rpm
Solenoid	
Hold-in Windings @ 12.2 Volts	12-20 amps
Pull-in Windings @ 12.2 Volts	60-90 amps

GENERATOR SPECIFICATIONS

Application	Description
Type	CS-128D

BATTERY SPECIFICATIONS

Application	Description
Cold Cranking Amps	550 amps (Cold Area : 610 amps)
Reserve Capacity Minimum	90 minutes
Load Test	270 amps
Replacement	85B-60
Minimum Voltage:	Estimated Temperature:
9.6	21°C (69.8°F)
9.4	20°C (68°F)
9.1	0°C (32°F)
8.8	-10°C (14°F)
8.5	-18°C (0°F)
8.0	Below -18°C (Below 0°F)

FASTENER TIGHTENING SPECIFICATIONS

Application	N•m	Lb•Ft	Lb•In
Battery Cable Nuts	15	11	-
Battery Carrier Tray Lower Bolts	10	-	89
Battery Carrier Tray Upper Bolts	20	15	-
Battery Retainer Clamp-to-Battery Rod Nuts	4	-	35
Battery Terminal Bolt	20	15	-
Battery-to-Generator Lead Nut	15	11	-
Generator Driveshaft Nut	100	74	-
Generator Lower Bracket-to-Engine Block Bolts	30	22	-
Generator Lower Bracket-to-Generator Nut	20	15	-
Generator Through Bolts	25	18	-
Generator-to-Cylinder Head Support Bracket Bolt	20	15	-
Generator-to-Intake Manifold and Cylinder Head Support Bracket Bolts	35	26	-
Generator-to-Intake Manifold Strap Bracket Bolt	20	15	-
Intake Manifold-to-Engine Block Bracket Bolts (Over Starter)	20	15	-
Starter Field Connector Nut	8	-	71
Starter Solenoid Assembly Screws	8	-	71
Starter Solenoid Terminal-to-Battery Cable Terminal Nut	7	-	62
Starter Solenoid Terminal-to-Ignition Solenoid Terminal Nut	6	-	53
Starter Through Bolts	6	-	53
Starter-to-Engine Block Mounting Bolt	45	33	-
Starter-to-Transmission Mounting Bolt	50	37	-

SCHEMATIC AND ROUTING DIAGRAMS

STARTING SYSTEM

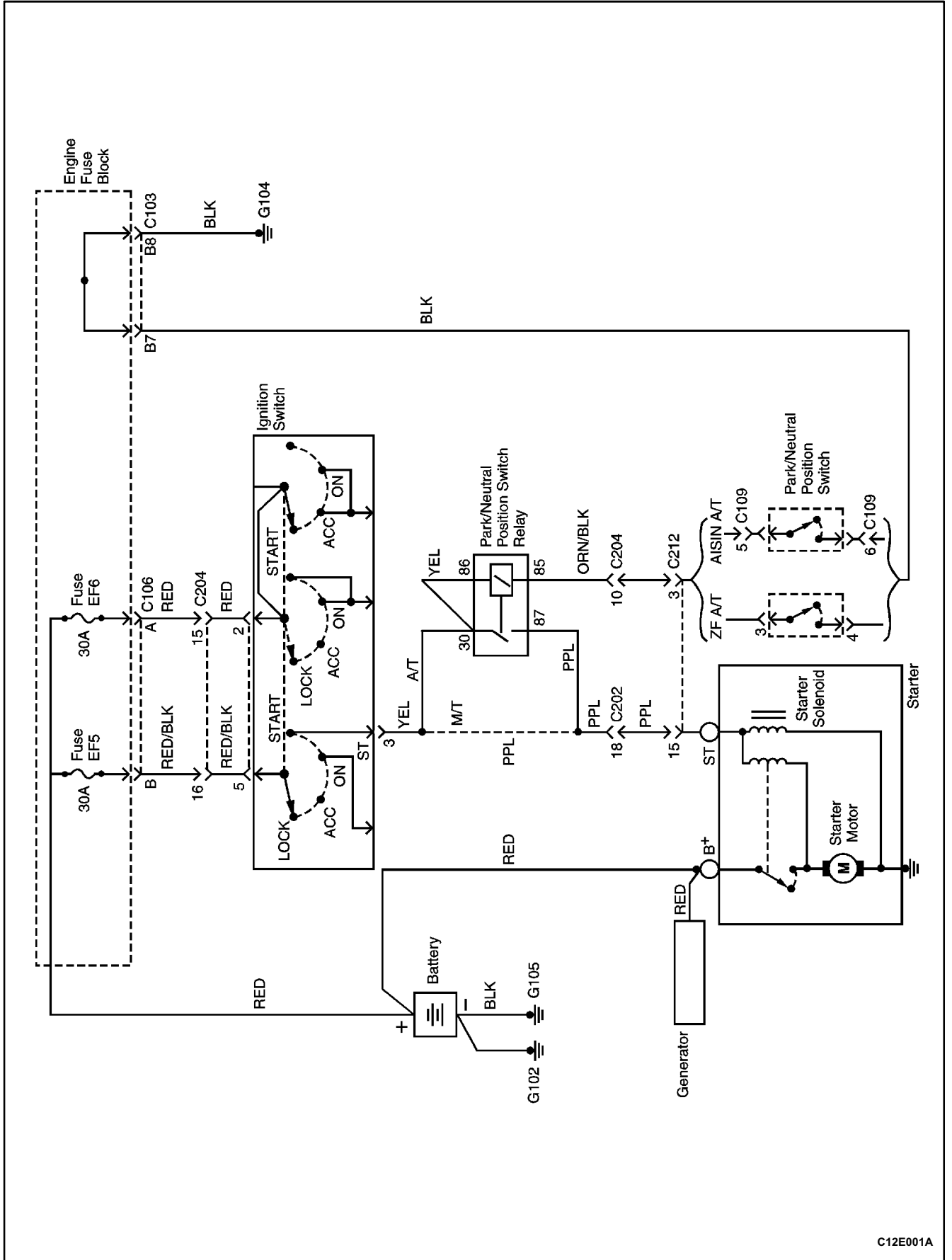

C12E001A

CHARGING SYSTEM

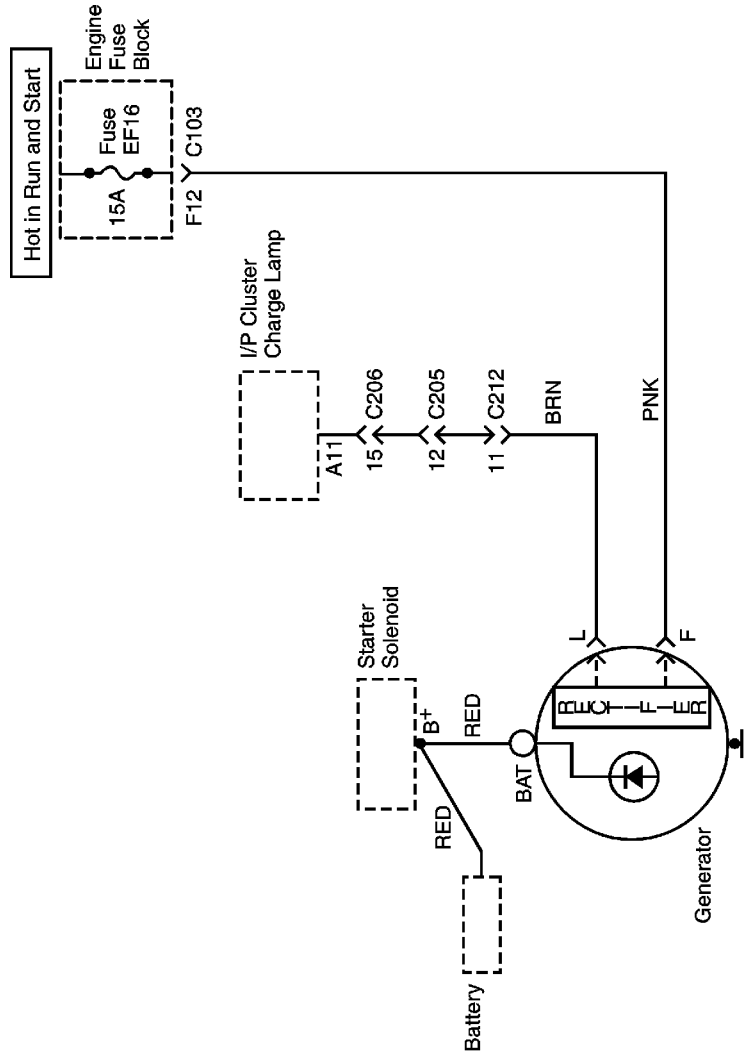

C12E002A

DIAGNOSIS**NO CRANK**

Step	Action	Value	Yes	No
1	1. Turn the headlamps ON. 2. Turn the dome lamps ON. 3. Turn the ignition to START. Did the lights dim or go out?	-	Go to Step 2	Go to Step 8
2	Check the battery state of charge. Is the green eye showing from the built-in hydrometer?	-	Go to Step 3	Go to "Charging Procedure"
3	1. Connect the voltmeter positive lead to the positive battery terminal. 2. Connect the voltmeter negative lead to the negative battery terminal. 3. Turn the ignition to START. Does the voltmeter indicate the value specified?	< 9.6 V	Go to "Charging Procedure"	Go to Step 4
4	1. Connect the voltmeter negative lead to the negative battery terminal. 2. Connect the positive voltmeter lead to the engine block. Does the voltmeter indicate the value specified?	> 0.5 V	Go to Step 5	Go to Step 6
5	Clean, tighten, or replace the negative battery cable. Is the repair complete?	-	System OK	-
6	1. Connect the voltmeter positive lead to the starter [B] terminal. 2. Connect the voltmeter negative lead to the negative battery terminal. Does the voltmeter indicate the value specified?	< 9 V	Go to Step 7	Go to Step 13
7	Clean, tighten, or replace the positive battery cable. Is the repair complete?	-	System OK	-
8	Inspect the engine fuse block fuse EF5. Is the fuse OK?	-	Go to Step 10	Go to Step 9
9	Replace the fuse EF6. Is the repair complete?	-	System OK	-
10	Check the connection at the starter [ST] terminal. Is the connection OK?	-	Go to Step 12	Go to Step 11
11	Clean or tighten the connection as needed. Is the repair complete?	-	System OK	-
12	1. Connect the voltmeter positive lead to the starter [ST] terminal. 2. Connect the voltmeter negative lead to the negative battery terminal. 3. Turn the ignition to START. Does the voltmeter indicate the value specified?	> 7 V	Go to Step 13	Go to Step 14
13	Repair or replace the starter as needed. Is the repair complete?	-	System OK	-
14	Determine the type of transaxle on the vehicle. Is the vehicle equipped with an automatic transmission?	-	Go to Step 15	Go to Step 32

NO CRANK (Continued)

Step	Action	Value	Yes	No
15	<ol style="list-style-type: none"> 1. Disconnect the Park Neutral (P/N) position switch relay. 2. Connect the negative voltmeter lead to the P/N relay connector terminal 86. 3. Connect the positive voltmeter lead to battery positive. Does the voltmeter indicate the value specified?	11-14 V	Go to <i>Step 20</i>	Go to <i>Step 16</i>
16	<ol style="list-style-type: none"> 1. Disconnect the P/N position switch. 2. Connect the negative voltmeter lead to the P/N position switch connector terminal 4. 3. Connect the positive voltmeter lead to battery positive. Does the voltmeter indicate the value specified?	11-14 V	Go to <i>Step 17</i>	Go to <i>Step 25</i>
17	<ol style="list-style-type: none"> 1. Jumper the P/N position switch connector terminals 3 and 4. 2. Connect the negative voltmeter lead to the P/N relay connector terminal 86. 3. Connect the positive voltmeter lead to battery positive. Does the voltmeter indicate the value specified?	11-14 V	Go to <i>Step 18</i>	Go to <i>Step 19</i>
18	Replace the neutral safety backup switch. Is the repair complete?	-	System OK	-
19	Repair the open wire between the P/N position switch connector terminal 3 and the P/N back-up relay connector terminal 85. Is the repair complete?	-	System OK	-
20	<ol style="list-style-type: none"> 1. Connect the positive voltmeter lead to the P/N back-up relay connector terminal 30. 2. Connect the voltmeter negative lead to ground. 3. Turn the ignition to START. Does the voltmeter indicate the value specified?	11-14 V	Go to <i>Step 21</i>	Go to <i>Step 27</i>
21	<ol style="list-style-type: none"> 1. Connect the positive voltmeter lead to the NSBU relay connector terminal 86. 2. Connect the voltmeter negative lead to ground. 3. Turn the ignition to START. Does the voltmeter indicate the value specified?	11-14 V	Go to <i>Step 22</i>	Go to <i>Step 26</i>
22	<ol style="list-style-type: none"> 1. Jumper connector terminals 30 and 87 of the P/N relay. 2. Turn the ignition to START. Does the starter crank?	-	Go to <i>Step 31</i>	Go to <i>Step 23</i>
23	Check for an open in the wire between the P/N relay connector terminal 87 and the starter "ST" terminal. Is the problem found?	-	Go to <i>Step 24</i>	Go to <i>Step 13</i>
24	Repair the wire as needed. Is the repair complete?	-	System OK	-
25	Repair the open wire between the P/N position switch connector terminal 4 and ground. Is the repair complete?	-	System OK	-

NO CRANK (Continued)

Step	Action	Value	Yes	No
26	Repair the open wire between the P/N relay connector terminal 86 and the ignition switch connector terminal 3. Is the repair complete?	-	System OK	-
27	1. Connect the voltmeter positive lead to the ignition switch connector terminal 5 by backprobing the connector. 2. Connect the voltmeter negative lead to ground. Does the voltmeter indicate the value specified?	11-14 V	Go to Step 29	Go to Step 28
28	Repair the open in the wiring between the engine block fuse EF5 and the ignition switch connector terminal 5. Is the repair complete?	-	System OK	-
29	1. Connect the voltmeter positive lead to the ignition switch connector terminal 3 by backprobing the connector. 2. Connect the voltmeter negative lead to ground. 3. Turn the ignition to START. Does the voltmeter indicate the value specified?	11-14 V	Go to Step 30	Go to Step 36
30	Repair the open in the wiring between the ignition switch connector terminal 3 and the P/N relay connector terminal 30. Is the repair complete?	-	System OK	-
31	Replace the P/N relay. Is the repair complete?	-	System OK	-
32	1. Connect the voltmeter positive lead to the ignition switch connector terminal 5 by backprobing the connector. 2. Connect the voltmeter negative lead to ground. Does the voltmeter indicate the value specified?	11-14 V	Go to Step 34	Go to Step 33
33	Repair the open in the wiring between the engine block fuse EF5 and the ignition switch connector terminal 5. Is the repair complete?	-	System OK	-
34	1. Connect the voltmeter positive lead to the ignition switch connector terminal 3 by backprobing the connector. 2. Connect the voltmeter negative lead to ground. 3. Turn the ignition to START. Does the voltmeter indicate the value specified?	11-14 V	Go to Step 35	Go to Step 36
35	Repair the open in the wiring between the ignition switch connector terminal 3 and the starter "ST" terminal. Is the repair complete?	-	System OK	-
36	Replace the ignition switch. Is the repair complete?	-	System OK	-

STARTER MOTOR NOISE

To correct starter motor noise during starting, use the following procedure:

Checks	Action
Check for a high-pitched whine during cranking before the engine fires. The engine cranks and fires properly.	The distance is too great between the starter pinion and the flywheel. Shimming the starter toward the flywheel is required.
Check for a high-pitched whine after the engine fires, as the key is being released. The engine cranks and fires properly. This intermittent complaint is often diagnosed as "starter hang-in" or "solenoid weak."	The distance is too small between the starter pinion and the flywheel. Shimming the starter away from the flywheel is required.
Check for a loud "whoop" after the engine fires but while the starter is still held engaged. The sound is like a siren if the engine is revved while the starter is engaged.	The most probable cause is a defective clutch. A new clutch will often correct this problem.
Check for a "rumble," a "growl," or, in severe cases, a "knock" as the starter is coasting down to a stop after starting the engine.	The most probable cause is a bent or an unbalanced starter armature. A new armature will often correct this problem.

If the complaint is noise, correction can be achieved by proper shimming as follows:

1. Check for a bent or a worn flywheel.
2. Start the engine and carefully touch the outside diameter of the rotating flywheel ring gear with chalk or a crayon to show the high point of the tooth runout. Turn the engine OFF and rotate the flywheel so that the marked teeth are in the area of the starter pinion gear.
3. Disconnect the negative battery cable to prevent the cranking of the engine.
4. Check the pinion-to-flywheel clearance by using a wire gauge of 0.5 mm (0.02 inch) minimum thickness or diameter. Center a pinion tooth between two flywheel teeth and the gauge. Do not gauge in the corners where a misleading larger dimension may be observed. If the clearance is under this minimum, shim the starter away from the flywheel.
5. If the clearance approaches 1.5 mm (0.06 inch) or more, shim the starter toward the flywheel. This condition is generally the cause of broken flywheel teeth or the starter housing. Shim the starter toward the flywheel by shimming only the outboard starter mounting pad. A shim of 0.40 mm (0.016 inch) thickness at this location will decrease the clearance by approximately 0.30 mm (0.012 inch). If normal starter shims are not available, plain washers or other suitable material may be used as shims.

BATTERY LOAD TEST

1. Check the battery for obvious damage, such as a cracked or broken case or cover, which could permit the loss of electrolyte. If damage is obvious, replace the battery.

Caution: Do not charge the battery if the hydrometer is clear or light yellow. Instead, replace the battery. If the battery feels hot or if violent gassing or spewing of electrolyte through the vent hole occurs, discontinue charging or reduce the charging rate to avoid personal injury.

Important: The battery temperature must be estimated by touch, taking into consideration the ambient temperature to which the battery has been exposed for the preceding few hours.

2. Check the hydrometer. If the green dot is visible, go to the load test procedure. If the indicator is dark but green is not visible, charge the battery. For charging a battery removed from the vehicle, refer to "Charging a Completely Discharged Battery" in this section.
3. Connect a voltmeter and a battery load tester across the battery terminals.
4. Apply a 300 ampere load for 15 seconds to remove the surface charge from the battery.
5. Remove the load.
6. Wait 15 seconds to let the battery recover.
7. Apply a 270 ampere load.
8. If the voltage does not drop below the minimum listed, the battery is good and should be reinstalled. If the voltage is less than the minimum listed, replace the battery. Refer to "Battery Specifications" in this section.

GENERATOR OUTPUT TEST

1. Perform the generator system test. Refer to "Generator System Check" in this section.
2. Replace the generator if it fails that test. Refer to "Generator" in the On-Vehicle Service portion of this section.
3. If the generator passes the test, perform the on-vehicle output test which follows.

Important: Always check the generator for output before assuming that a grounded "L" terminal circuit has damaged the regulator.

4. Attach a digital multimeter, an ammeter, and a carbon pile load to the vehicle.

Important: Be sure the vehicle battery is fully charged, and the carbon pile load is turned off.

5. With the ignition switch in the off position, check and record the battery voltage.
6. Remove the harness connector from the generator.
7. Turn the ignition switch to the RUN position with the engine not running.
8. Use a digital multimeter to check for voltage in the harness connector "L" terminal. The reading should be near the specified battery voltage of 12 volts.
9. If the voltage is too low, check the indicator "L" terminal circuits for open and grounded circuits causing voltage loss. Correct any open wires, terminal connections, etc., as necessary. Refer to "Charging System" in this section.
10. Attach the generator harness connector.
11. Run the engine at a moderate idle, and measure the voltage across the battery terminals. The reading should be above that recorded in step 15 but less than 16 volts. If the reading is over 16 volts or below the previous reading, replace the generator. Refer to "Generator" in the On-Vehicle Service portion of this section.
12. Run the engine at a moderate idle, and measure the generator amperage output.
13. Turn on the carbon pile, and adjust it to obtain the maximum amps while maintaining the battery voltage above 13 volts. If the reading is within 15 amps of the generator's rating listed on the generator, the generator is good. If not, replace the generator. Refer to "Generator" in the On-Vehicle Service portion of this section.
14. With the generator operating at the maximum output, measure the voltage between the generator housing and the battery negative terminal. The voltage drop should be 0.5 volt or less. If the voltage drop is more than 0.5 volt, check the ground path from the generator housing to the negative battery cable.
15. Check, clean, tighten, and recheck all of the ground connections.

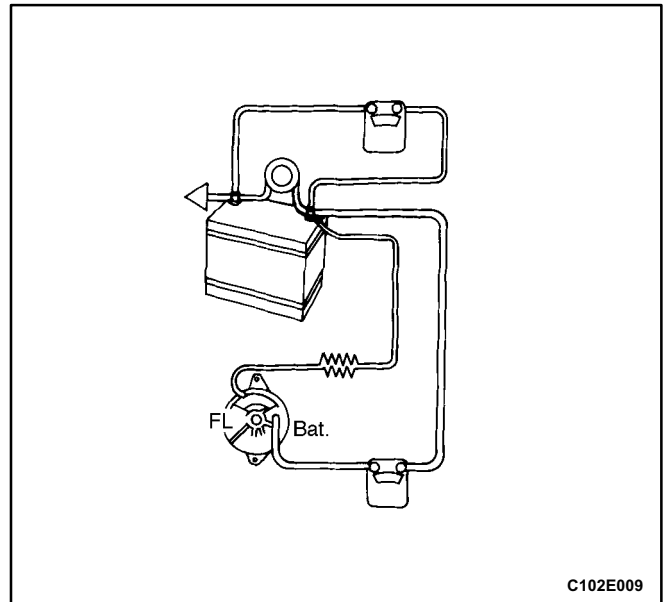

GENERATOR SYSTEM CHECK

When operating normally, the generator indicator lamp will come on when the ignition switch is in the RUN position and go out when the engine starts. If the lamp operates abnormally or if an undercharged or overcharged battery condition occurs, the following procedure may be used to diagnose the charging system. Remember that an undercharged battery is often caused by accessories being left on overnight or by a defective switch that allows a lamp, such as a trunk or a glove box lamp, to stay on.

Diagnose the generator with the following procedure:

1. Visually check the belt and the wiring.
2. With the ignition switch in the RUN position and the engine stopped, the charge indicator lamp should be on. If not, detach the harness at the generator and ground the "L" terminal in the harness with a 5ampere fused jumper lead.
 - If the lamp lights, replace the generator. Refer to "Generator" in the On-Vehicle Service portion of this section.
 - If the lamp does not light, locate the open circuit between the ignition switch and the harness connector. The indicator lamp bulb may be burned out.
3. With the ignition switch in the RUN position and the engine running at moderate speed, the charge indicator lamp should be off. If not, detach the wiring harness at the generator.
 - If the lamp goes off, replace the generator. Refer to "Generator" in the On-Vehicle Service portion of this section.
 - If the lamp stays on, check for a short to ground in the harness between the connector and the indicator lamp.

Important: Always check the generator for output before assuming that a grounded "L" terminal circuit has damaged the regulator. Refer to "Generator" in the Unit Repair portion of this section.

MAINTENANCE AND REPAIR

ON-VEHICLE SERVICE

GENERATOR - 95 AMP

Removal Procedure

1. Disconnect the negative battery cable.
2. Disconnect the manifold air temperature (MAT) connector from the air intake tube.
3. Remove the air intake tube.

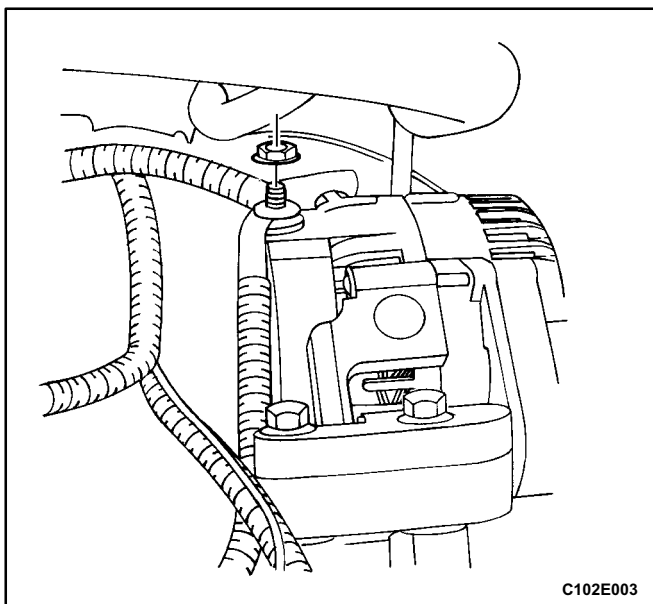
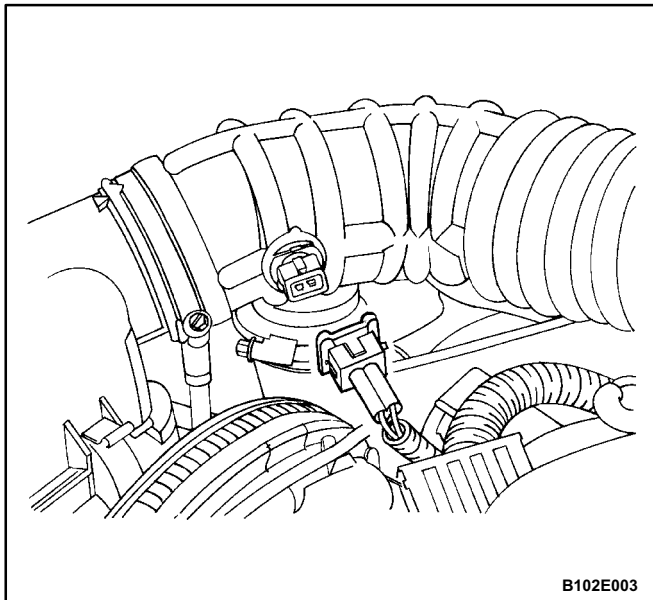

4. Remove the nut from the generator lead to the battery and disconnect the lead.
5. Disconnect the harness connector from the back of the generator.

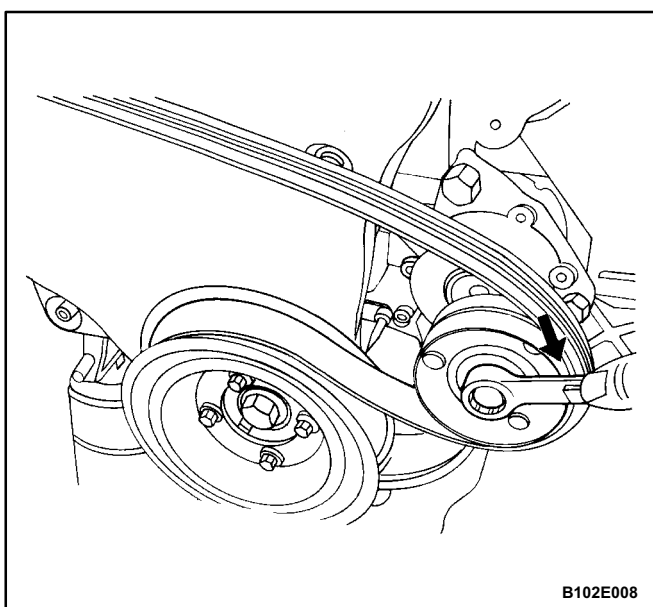

6. Remove the serpentine accessory drive belt. Refer to *Section 6B, Power Steering Pump*.

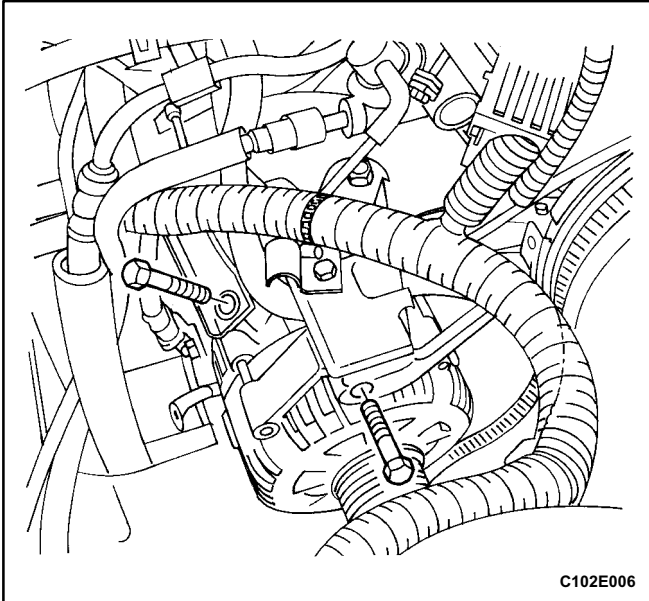

7. Remove the generator-to-intake manifold and cylinder head support bracket bolts, and the generator-to-intake manifold strap bracket bolt.
8. Raise the vehicle and remove the bolts that hold the generator lower bracket to the engine.

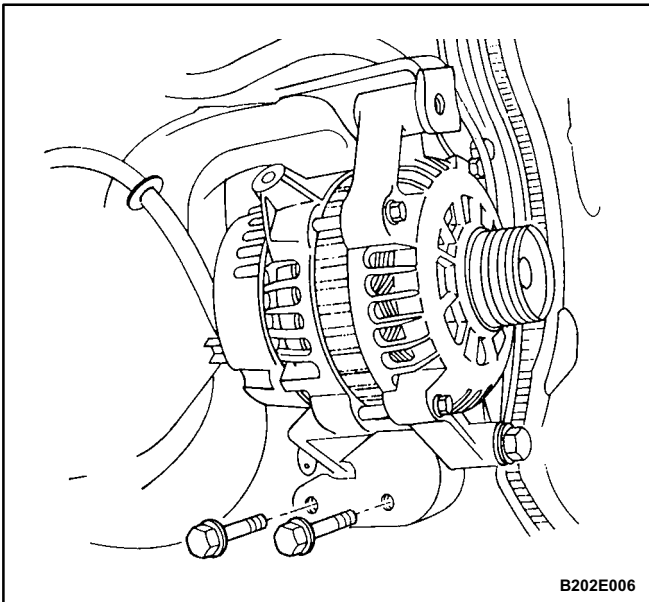

9. Carefully remove the generator with the lower bracket attached.
10. Remove the generator lower support bracket bolt and nut.

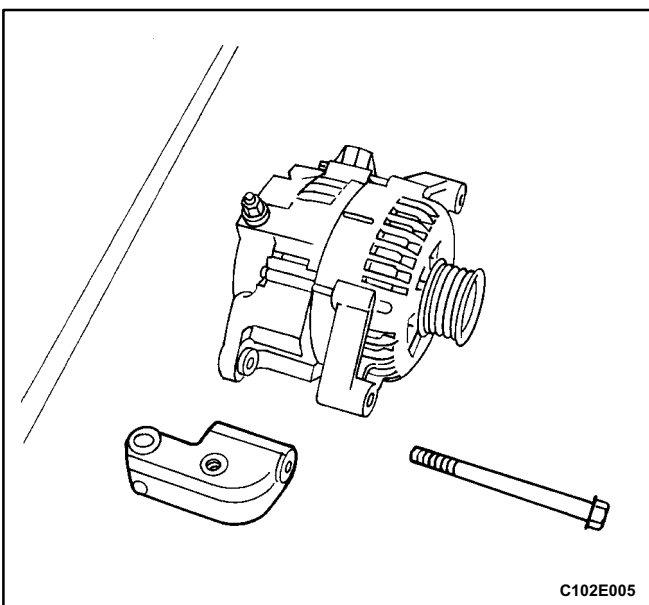

Installation Procedure

1. Install the generator to the lower bracket with the bolts.
2. Install the nut and the washer on the lower bracket-to-generator bolt.

Tighten

Tighten the lower bracket-to-generator nut to 20 N•m (15 lb•ft).

3. Install the generator and the lower support bracket assembly to the engine block with the bolts.

Tighten

Tighten the generator lower bracket-to-engine block bolts to 30 N•m (22 lb•ft).

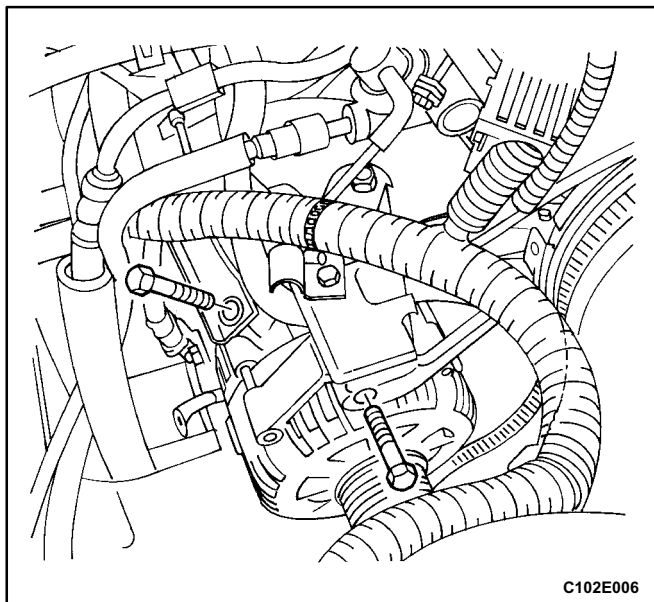

4. Lower the vehicle and install the generator-to-intake manifold and cylinder head support bracket bolts.

Tighten

Tighten the generator-to-intake manifold and cylinder head support bracket bolts to 35 N•m (26 lb•ft).

5. Install the generator-to-intake manifold strap bracket bolt.

Tighten

Tighten the generator-to-intake manifold strap bracket bolt to 20 N•m (15 lb•ft).

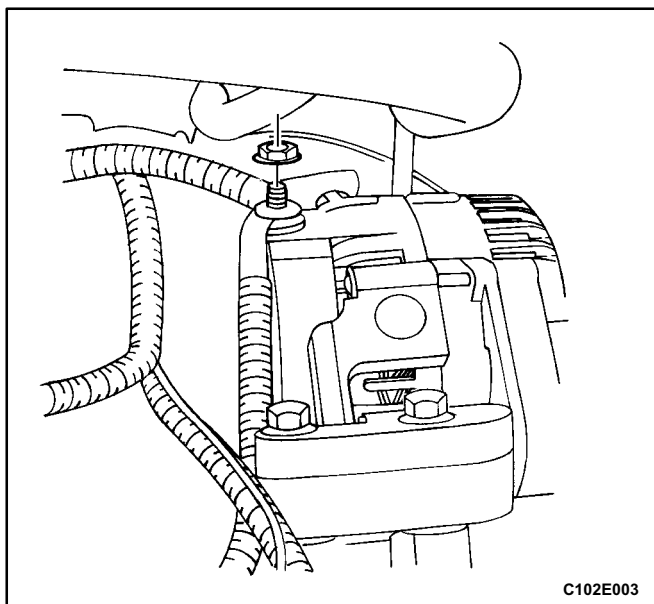

6. Connect the harness connector to the back of the generator.

7. Connect the battery lead to the generator and install the nut.

Tighten

Tighten the battery-to-generator lead to 15 N•m (11 lb•ft).

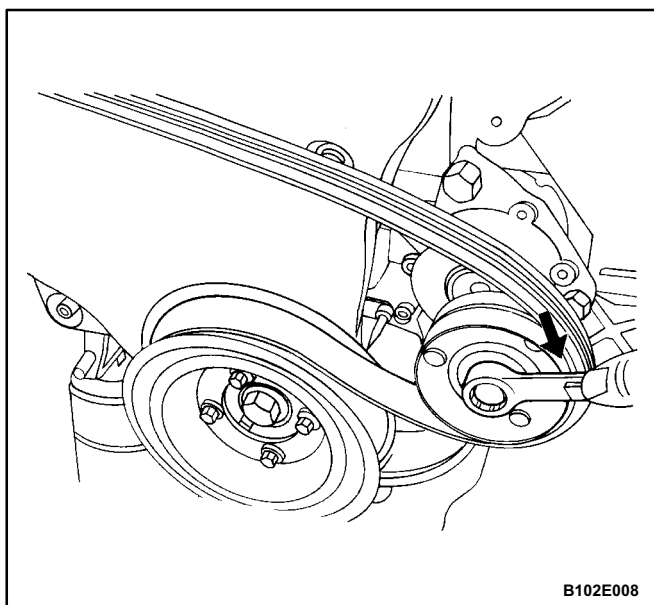

8. Install the serpentine accessory drive belt. Refer to *Section 6B, Power Steering Pump*.

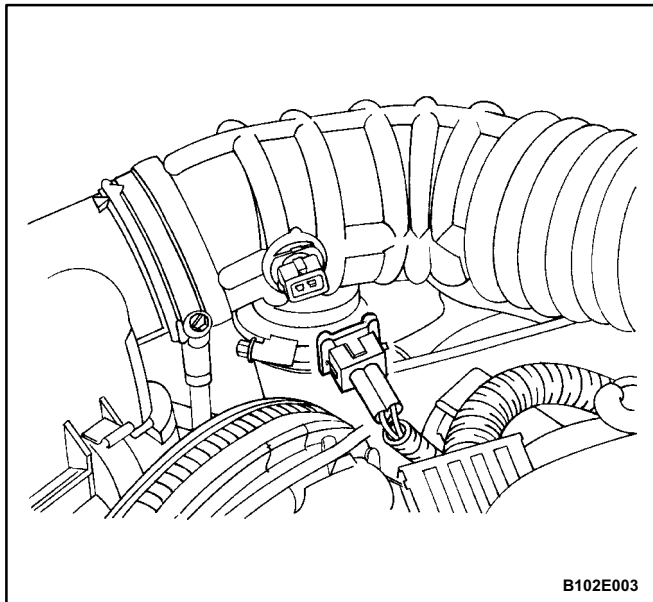

B102E003

9. Install the air intake tube and connect the MAT electrical connector.

10. Connect the negative battery cable.

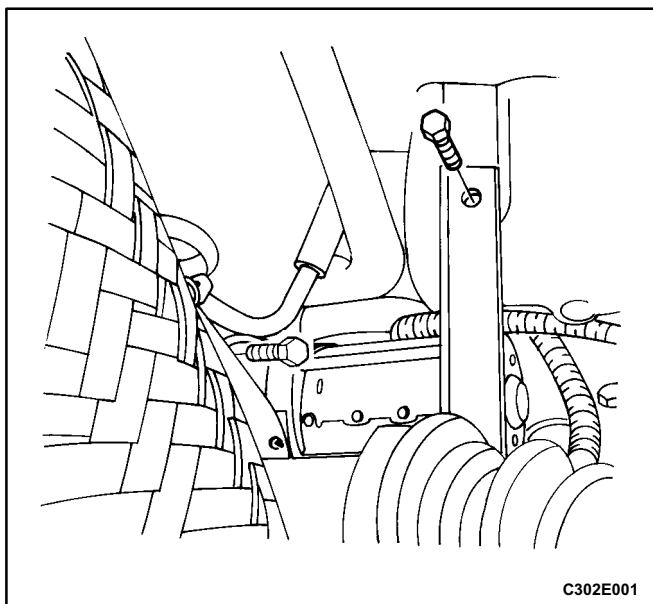

C302E001

STARTER - PG 150S

Removal Procedure

1. Remove the engine intake manifold-to-engine block strap bracket over the starter.

2. Remove the starter-to-transmission mounting bolt.

3. Remove the starter-to-engine block mounting bolt.

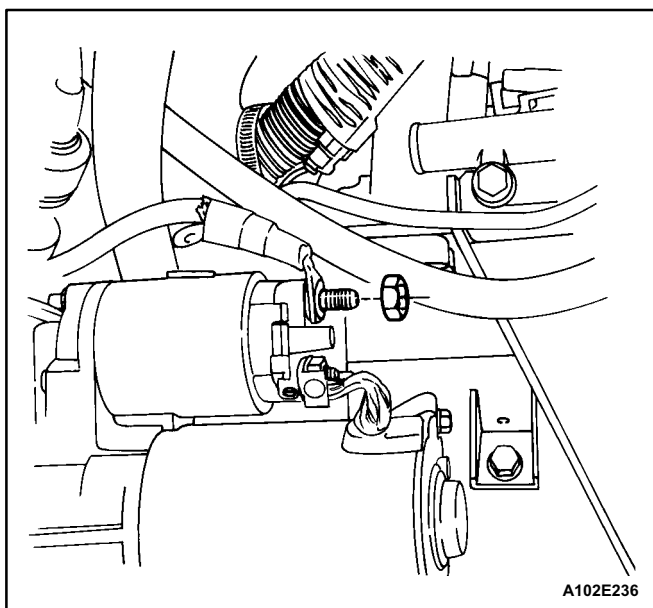

A102E236

4. Remove the starter solenoid nuts to disconnect the electrical cable.

5. Remove the starter assembly.

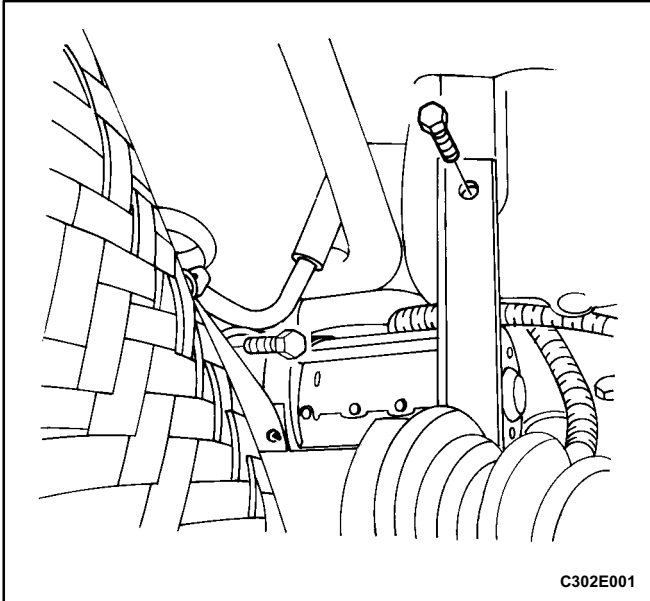

Installation Procedure

1. Place the starter assembly in position.
2. Install the upper and the lower starter mounting bolts.

Tighten

Tighten the starter-to-engine block mounting bolt to 45 N•m (33 lb•ft).

Tighten

Tighten the starter-to-transmission mounting bolt to 50 N•m (37 lb•ft).

3. Install the engine intake manifold-to-engine block strap bracket over the starter.

Tighten

Tighten the engine strap bracket over the starter to 20 N•m (15 lb•ft).

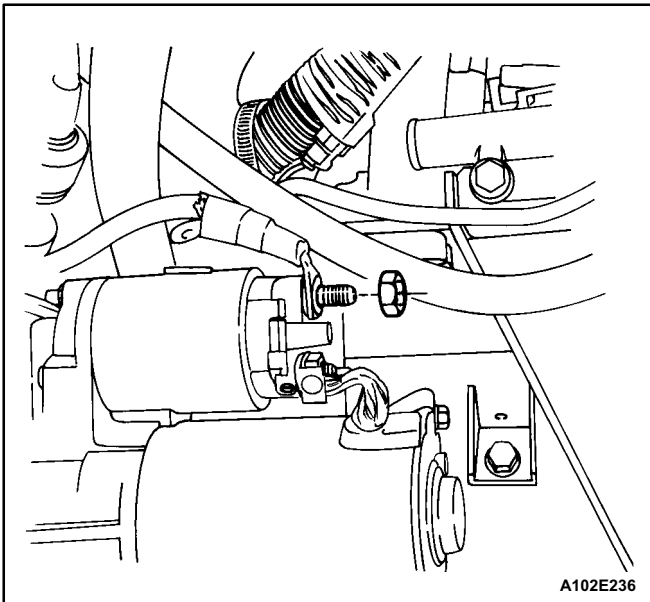

4. Position the starter electrical wire on the solenoid terminal.
5. Install the starter solenoid terminal-to-ignition solenoid terminal nut.

Tighten

Tighten the nut to 6 N•m (53 lb•in).

6. Install the starter solenoid terminal-to-battery cable terminal nut.

Tighten

Tighten the nut to 7 N•m (62 lb•in).

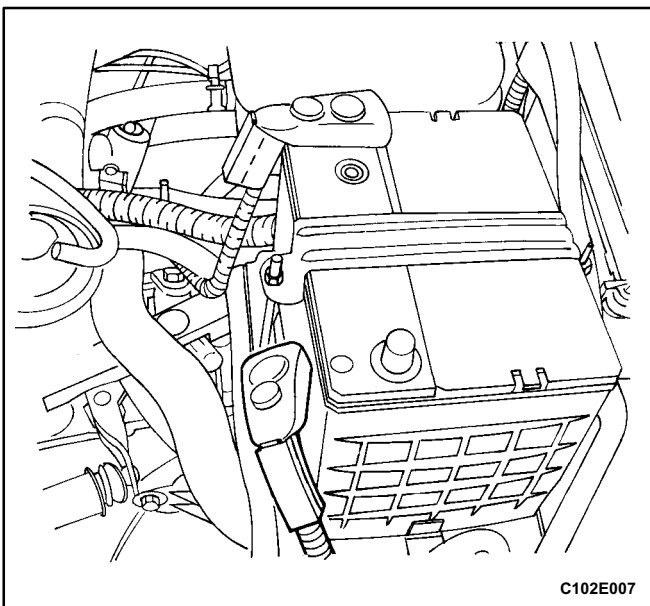

BATTERY/BATTERY TRAY

Removal Procedure

1. Disconnect the negative battery cable.

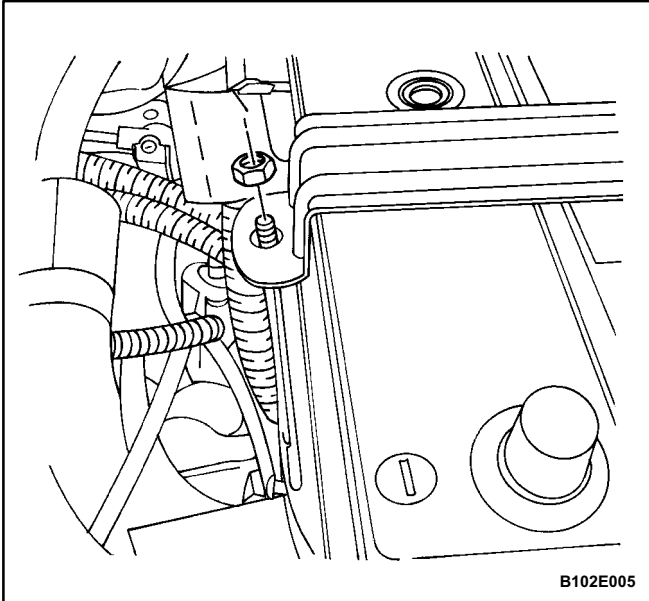

2. Disconnect the positive battery cable.
3. Remove the nuts from the battery rods that fasten the battery hold-down bar clamp.

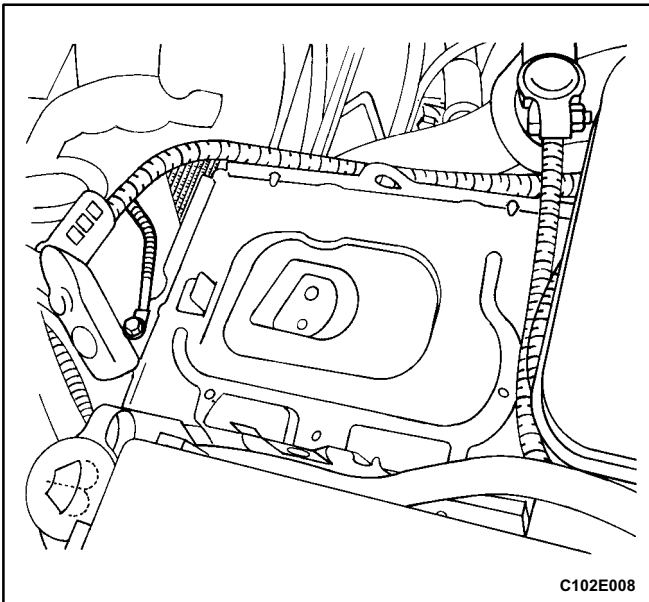

4. Check the battery carrier tray for obvious cracks or damage.
5. Detach the carrier tray if necessary by removing the battery carrier tray upper bolts, including the bolt of the battery terminal.
6. Remove the battery carrier tray lower bolts.

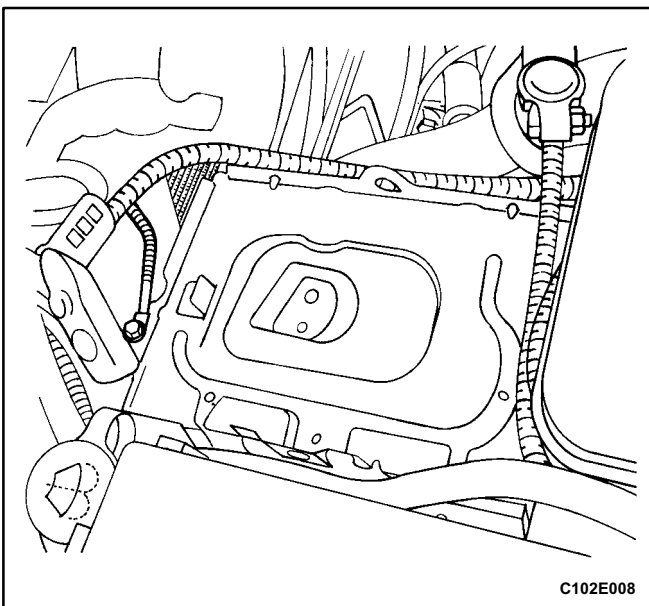

Installation Procedure

1. Install the battery carrier by fastening the carrier tray upper and the lower bolts.

Tighten

Tighten the battery carrier tray upper bolts, including the battery terminal bolts to 20 N•m (15 lb•ft).

Tighten

Tighten the battery carrier tray lower bolts to 10 N•m (89 lb•in).

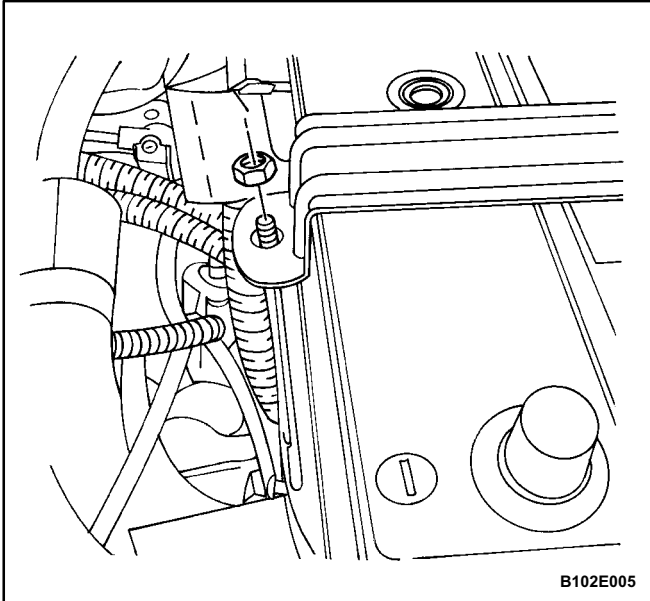

2. Install the battery into the tray.
3. Fasten the bar clamp to the battery by loosely attaching the battery rods from the battery tray cutouts through the bar clamp holes, and loosely tightening the nuts.

Tighten

Tighten the battery retainer clamp-to-battery rod nuts to 4 N•m (35 lb•in).

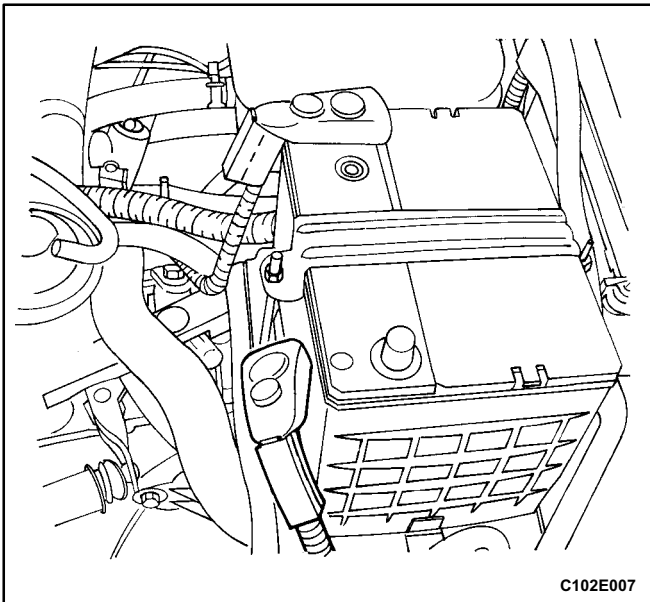

4. Connect the positive battery cable.
5. Connect the negative battery cable.

Tighten

Tighten the battery cable nuts to 15 N•m (11 lb•ft).

UNIT REPAIR

STARTER MOTOR

Disassembly Procedure

1. Remove the starter. Refer to "Starter" in the OnVehicle Service portion of this section.
2. Remove the starter through-bolts.

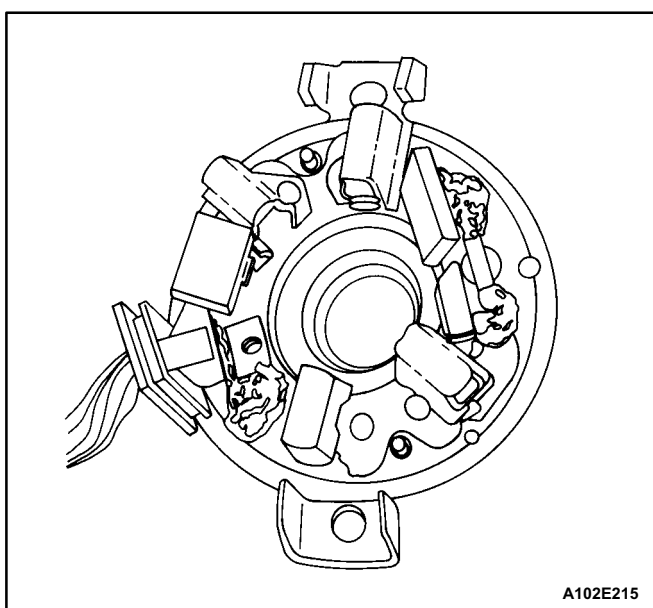
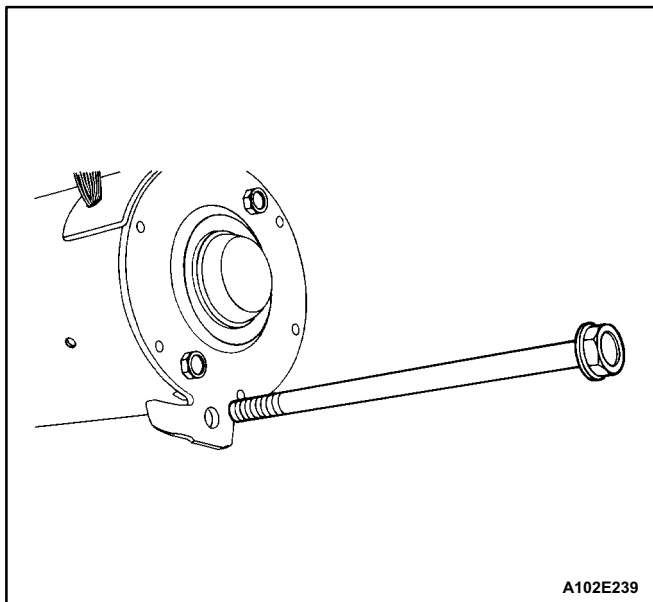

3. Remove the commutator end frame and brush holder assembly.
4. Inspect the brushes, the pop-out springs, and the brush holders for wear and damage. Replace the assembly if needed.

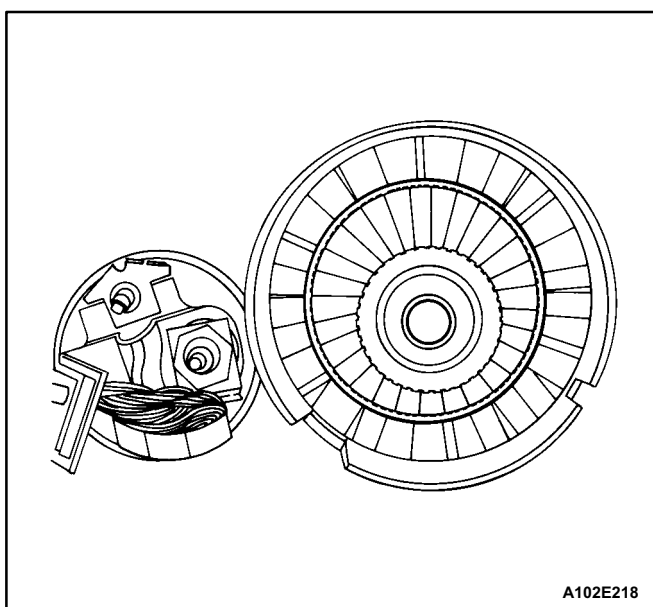

5. Check the armature to see if it turns freely. If the armature does not turn freely, break down the assembly immediately, starting with Step 12 of this procedure. Otherwise, give the armature a no-load test.

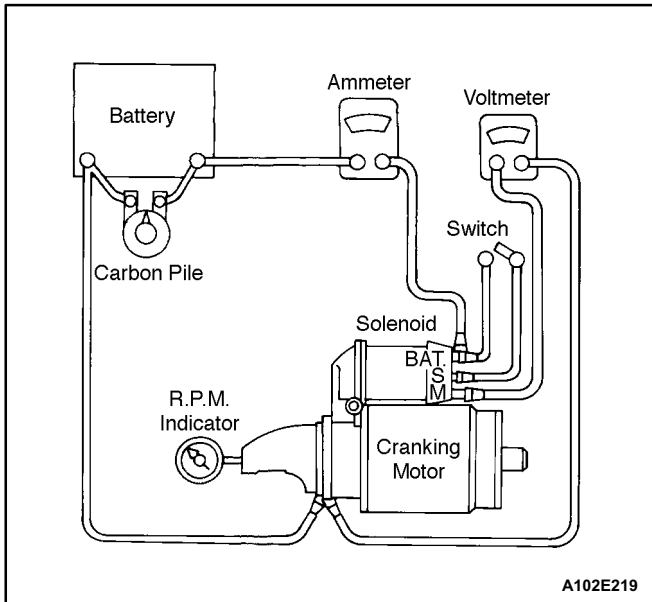

Important: If the specified current draw does not include the solenoid, deduct from the armature reading the specified current draw of the solenoid hold-in winding.

6. To begin the no-load test, close the switch and compare the RPM, the current, and the voltage readings with the specifications. Refer to "Starter Specifications" in this section. Make disconnections only with the switch open. Use the test results as follows.

- 6.1 Rated current draw and no-load speed indicate the normal condition of the starter motor.
- 6.2 Low free speed and high current draw indicate too much friction caused by tight, dirty or worn bearings, or a bent armature shaft; a shorted armature, or a shorted armature and fields.

Notice: Complete the testing in a minimum amount of time to prevent overheating, and thus damaging the solenoid.

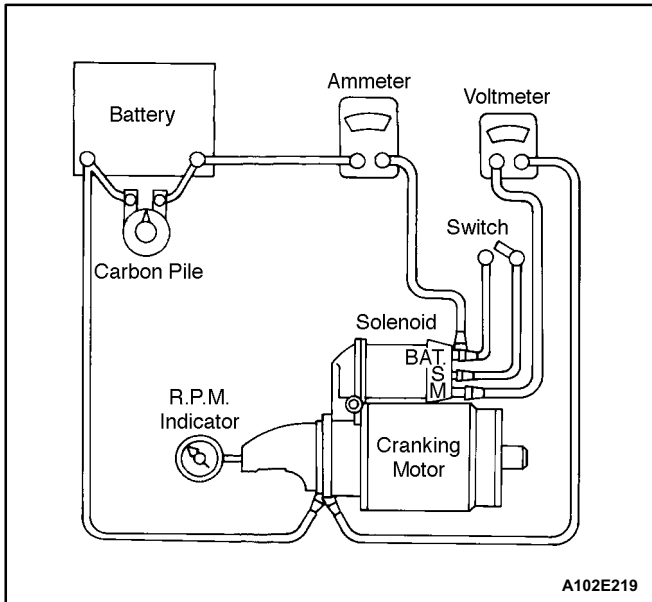

- 6.3 Failure to operate with high current draw indicates a direct ground in the terminal or fields, or "frozen" bearings.
- 6.4 Failure to operate with no current draw indicates an open field circuit, open armature coils, broken brush springs, worn brushes, high insulation between the commutator bars, or other causes which would prevent good contact between the brushes and the commutator.
- 6.5 Low no-load speed and low current indicate high internal resistance and high current draw, which usually mean shorted fields.

7. Remove the solenoid assembly screws.

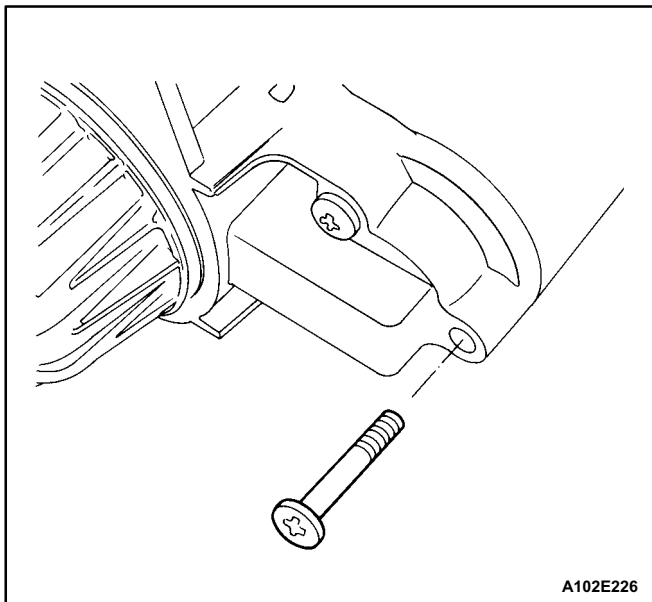

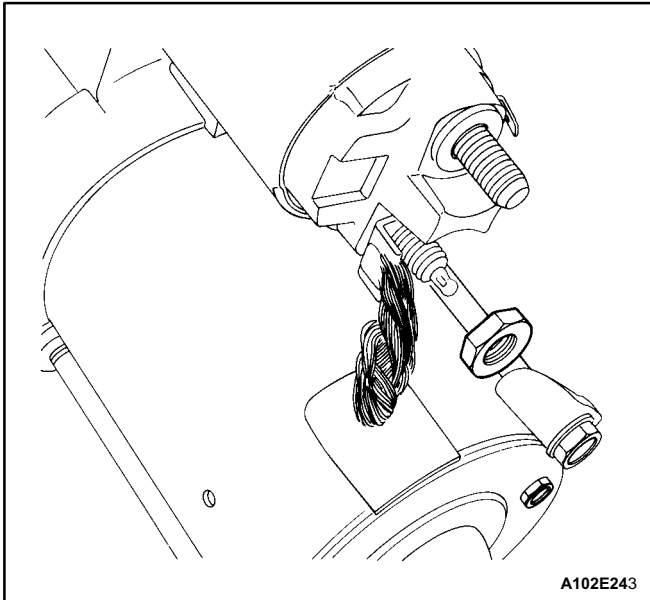

8. Remove the field connector nut. Disconnect the field connector.

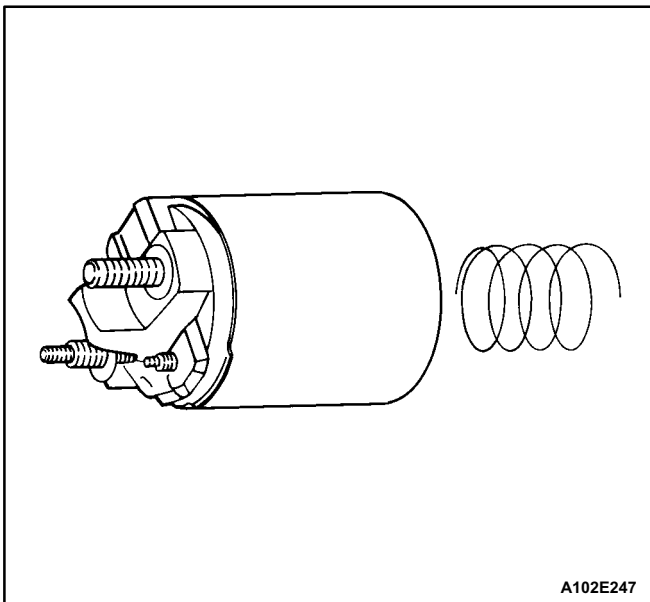

9. Rotate the solenoid 90 degrees and remove it along with the plunger return spring.

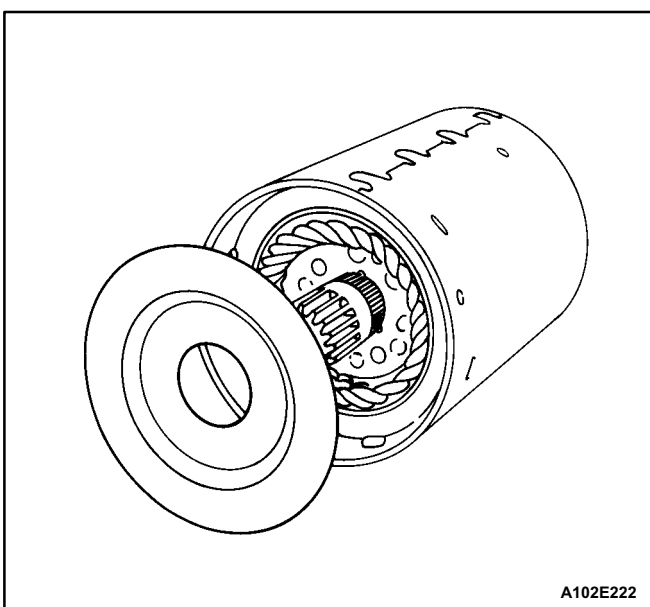

10. Slide the field frame with enclosed armature assembly away from the starter assembly.
11. Remove the shield.

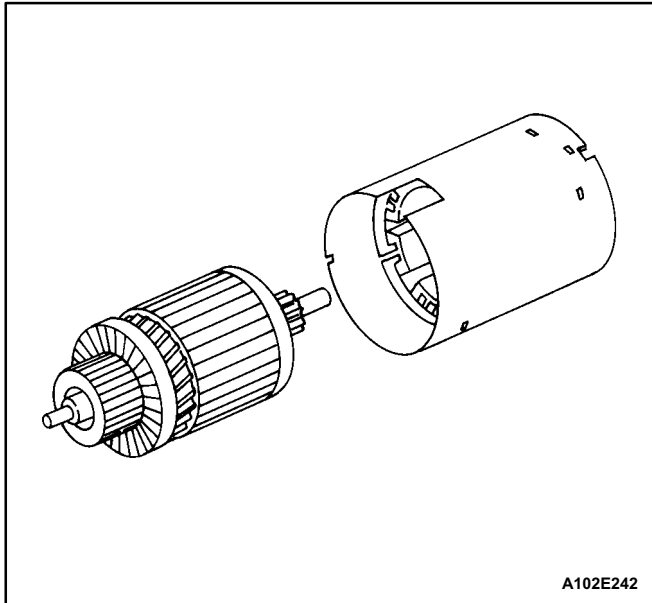

12. Separate the field frame from the armature.

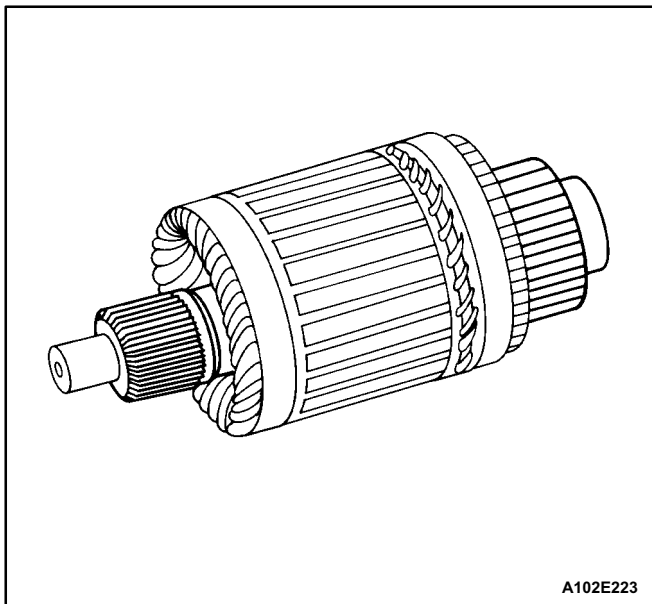

13. Inspect the shaft, the bearing, and the pinion for discoloration, damage, or wear. Replace if necessary.
14. Inspect the points where the armature conductors join the commutator bars. Make sure they have a good connection. A burned commutator bar is usually evidence of a poor connection.
15. If test equipment is available, check the armature for short circuits by placing it on a growler, and holding back a saw blade over the armature core while the armature is rotated. If the saw blade vibrates, replace the armature.
16. Recheck after cleaning between the commutator bars. If the saw blade vibrates, replace the armature.

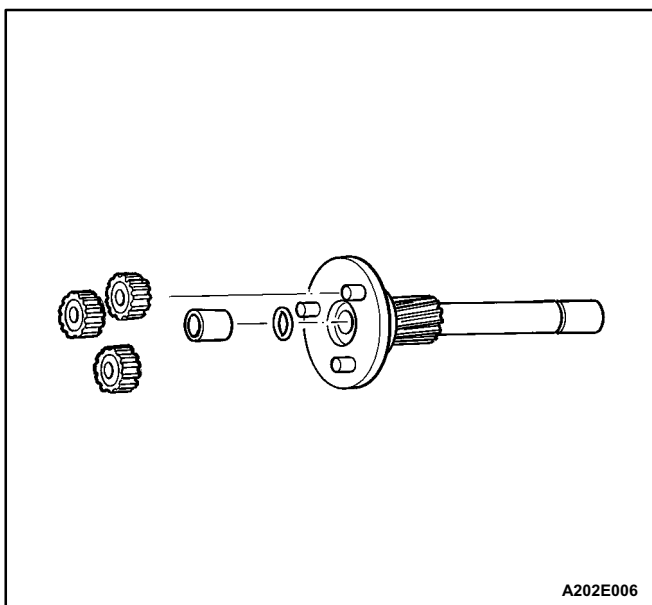

17. Remove the gears, the bushing, and the washer.
18. Remove the cushion and driveshaft assembly from the starter housing.

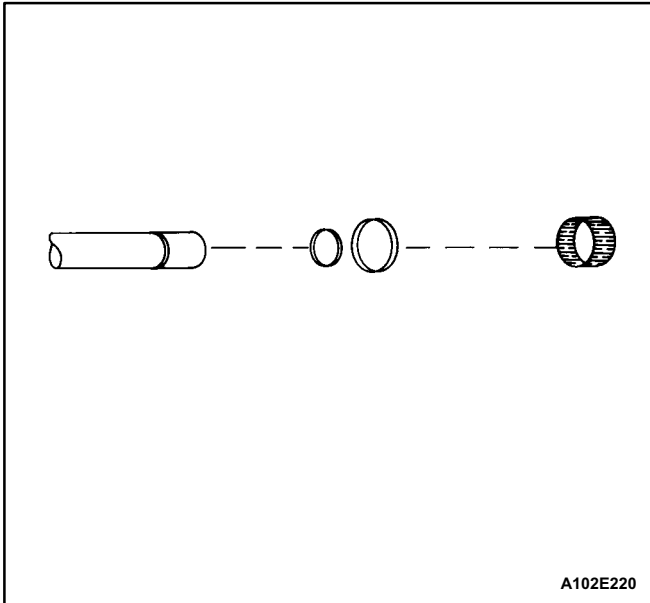

19. Disassemble the driveshaft assembly by first separating the needle bearing from the driveshaft.
20. Remove the collar and the locking ring from the groove in the driveshaft.

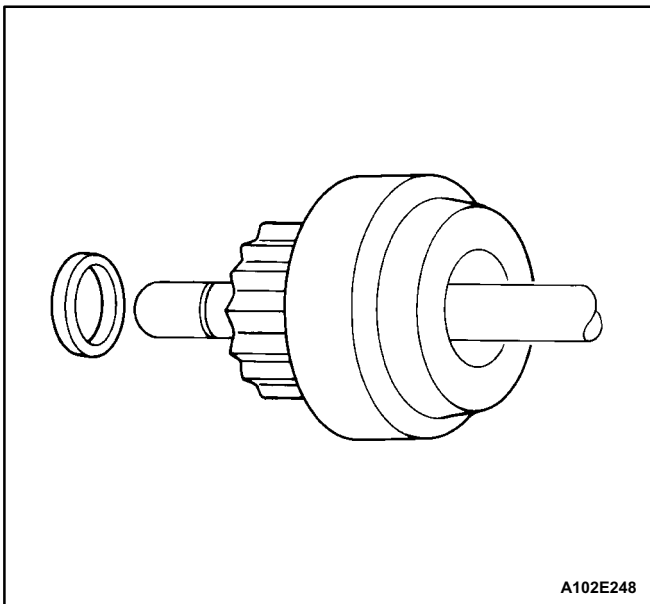

21. Remove the pinion stop and the drive from the driveshaft.

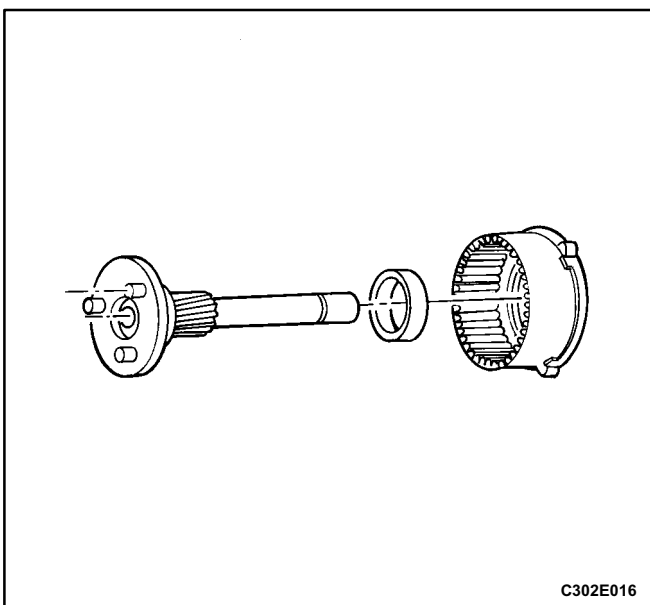

22. Remove the gear support and collar from the driveshaft.

23. If not done in the previous steps, remove the screws holding the solenoid assembly into the housing, and remove the nut from the field coil connector.

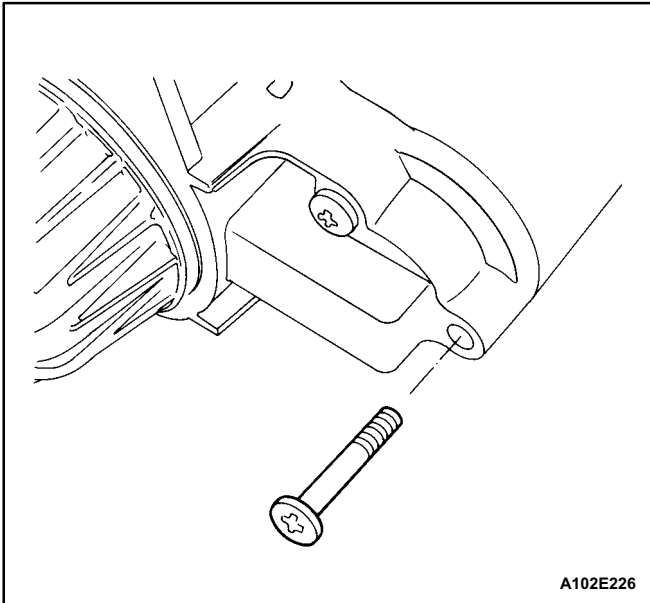

A102E226

24. Rotate the solenoid 90 degrees and remove it along with the return spring.

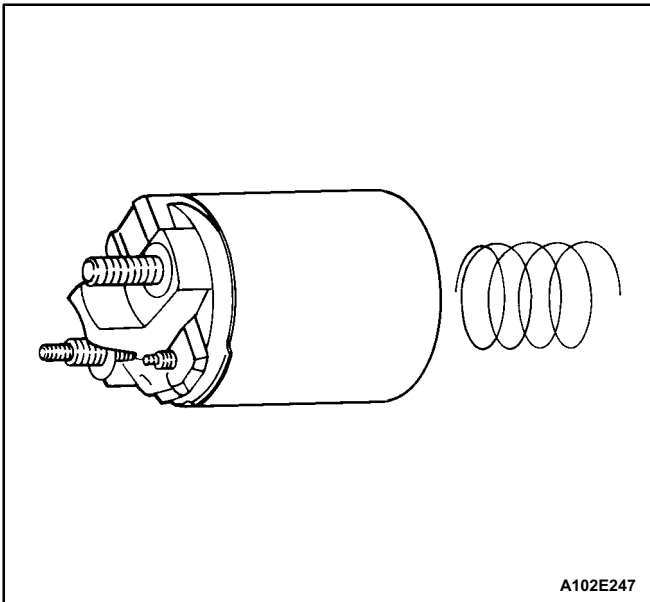

A102E247

25. Remove the plunger with the boot and the shift lever assembly.

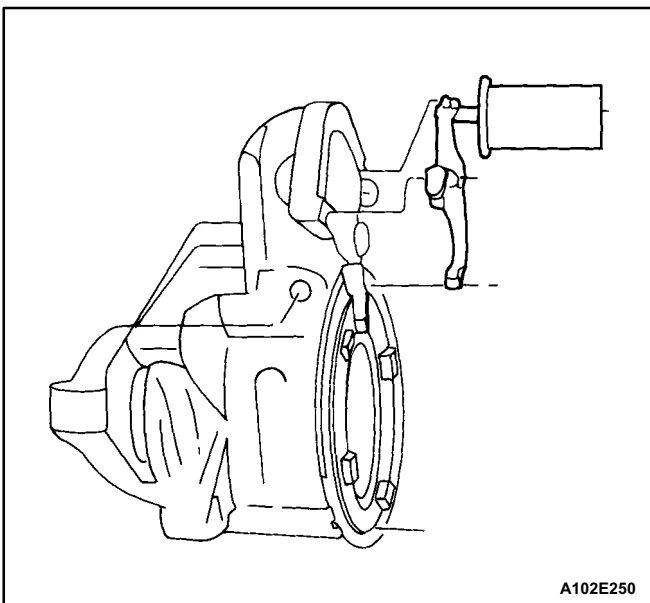

A102E250

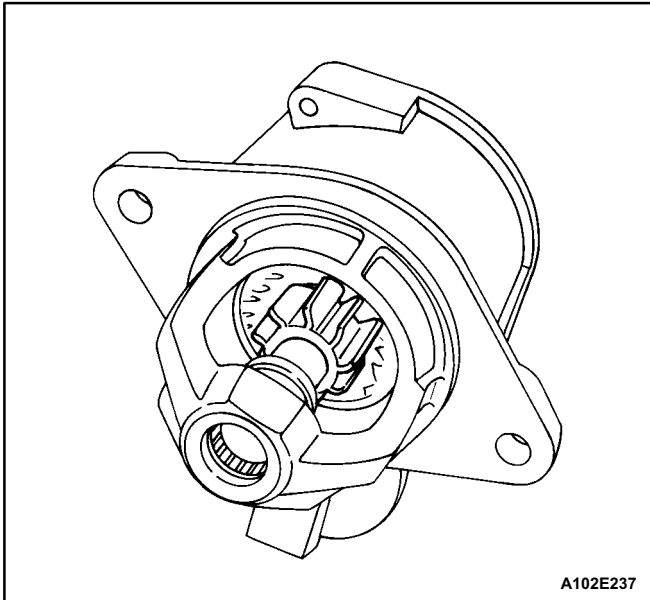

Notice: The pinion clearance must be correct to prevent the buttons on the shift lever yoke from rubbing on the clutch collar during the cranking.

26. When the starter motor is disassembled and the solenoid is replaced, it is necessary to check the pinion clearance.

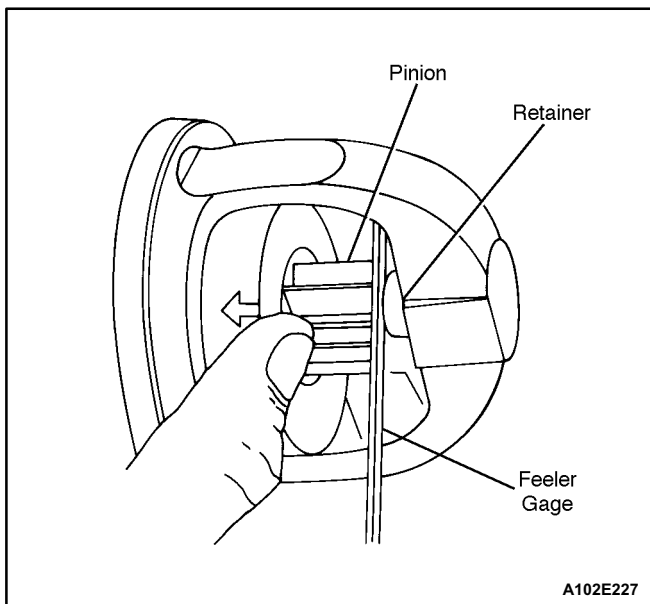

27. Disconnect the motor field coil connector from the solenoid motor terminal and carefully insulate the connector.

28. Connect one 12 volt battery lead to the solenoid switch terminal and the other to the starter frame.

29. Flash a jumper lead momentarily from the solenoid motor terminal to the starter frame, allowing shifting of the pinion in the cranking position, where it will remain until the battery is disconnected.

Important: A means for adjusting the pinion clearance is not provided on the starter motor. If the clearance does not fall within the limits, check for improper installation and replace all worn parts.

30. Push the pinion back as far as possible to take up any movement, and check the clearance with a feeler gauge. The clearance should be 0.25 to 3.56 mm (0.01 to 0.14 inch).

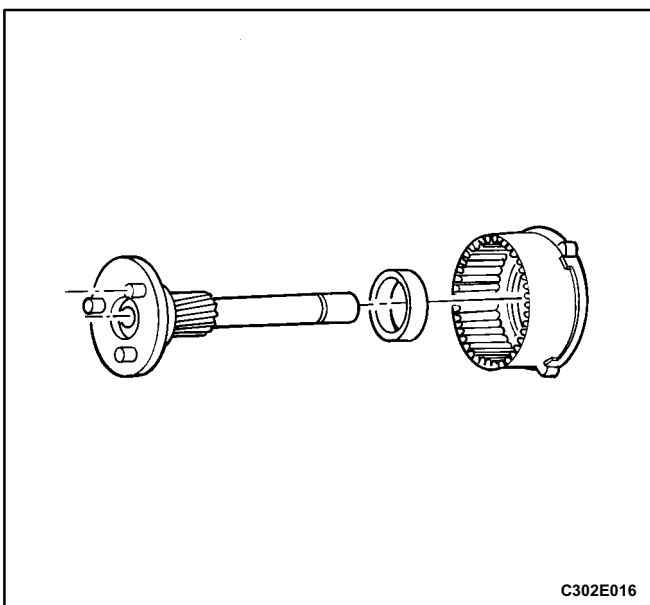

Assembly Procedure

1. Clean all of the starter motor parts, but do not use grease-dissolving solvents for cleaning the armature and the field coils.
2. Lubricate the gears. To reassemble the solenoid only, go to Step 7. To reassemble the starter and the solenoid, go to Step 3.
3. If full disassembly of the starter and the solenoid was performed, begin reassembly by placing the gear support and collar on the driveshaft assembly.

4. Install the drive and the pinion stop on the driveshaft.

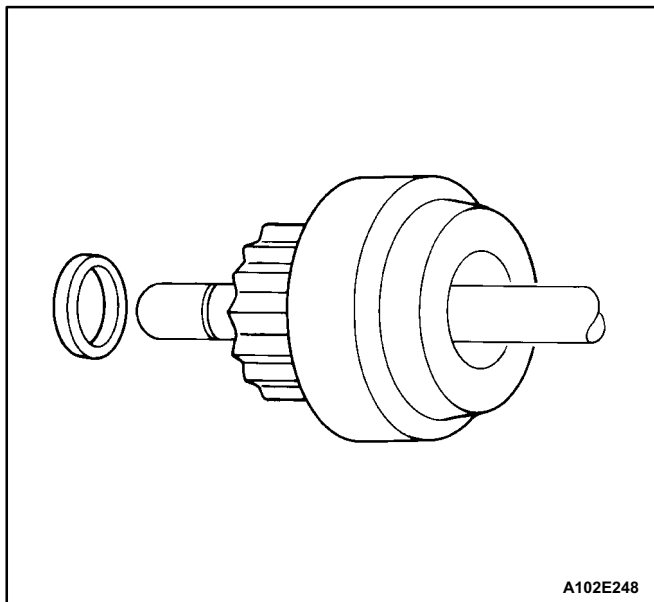

5. Install the lock ring into the groove on the driveshaft and insert the collar.
6. Install the needle bearing.

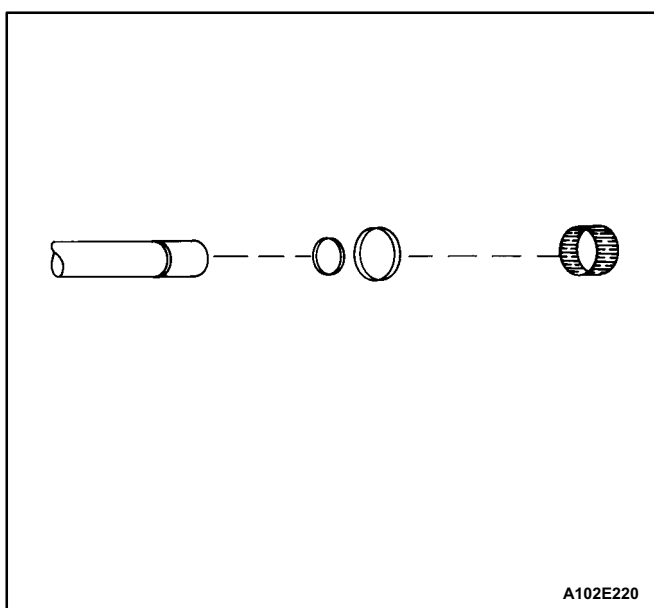

7. Install the shift lever assembly with the plunger and the boot.

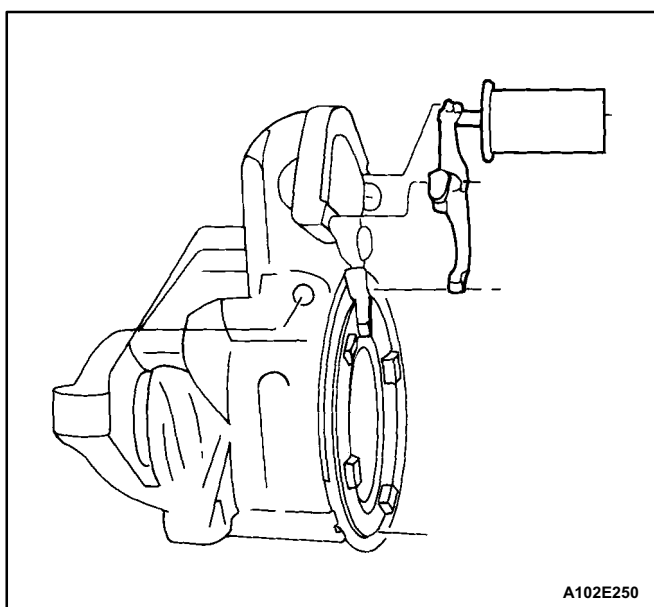

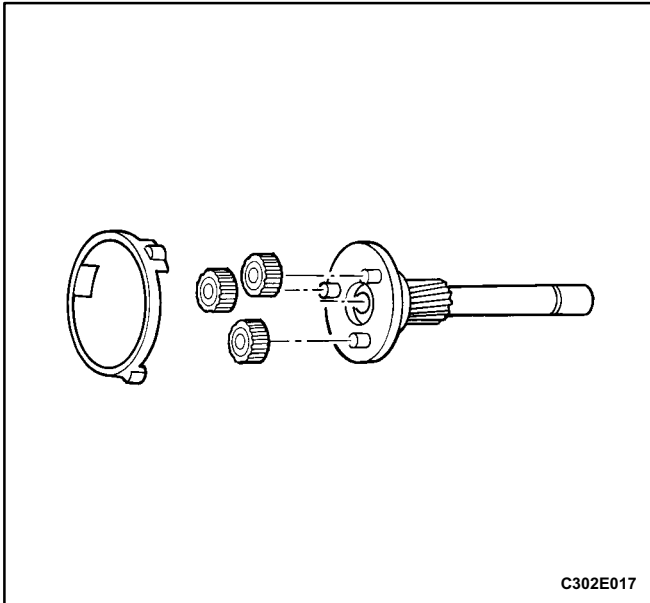

8. Lubricate the gears and install the driveshaft assembly.
9. Install the cushion and the gears.

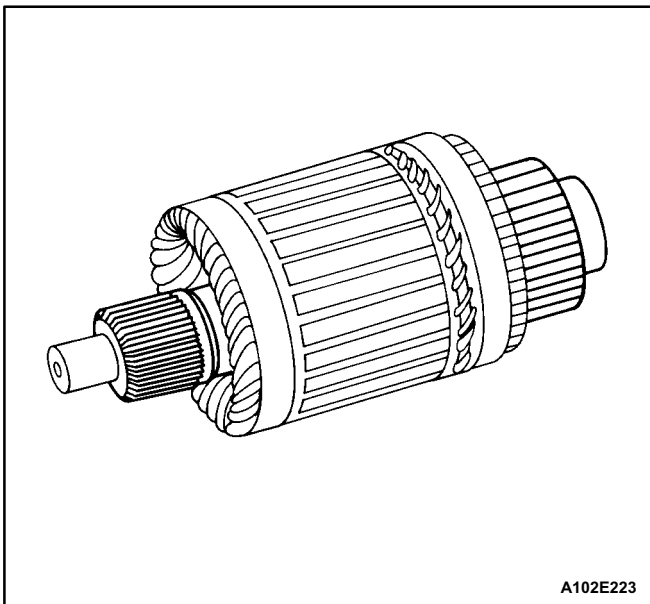

10. Lubricate the drive end of the armature shaft and install the new gear and the bearing, if needed.

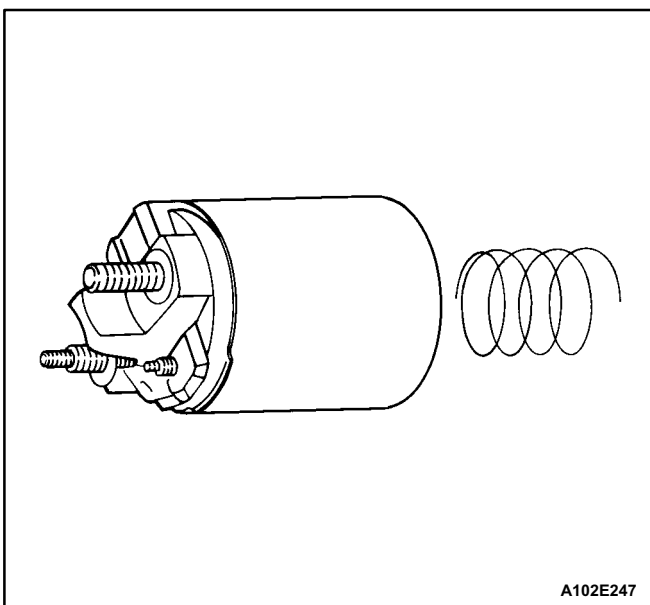

11. Position the solenoid assembly and the return spring against the plunger, applying sealer to the solenoid flange.

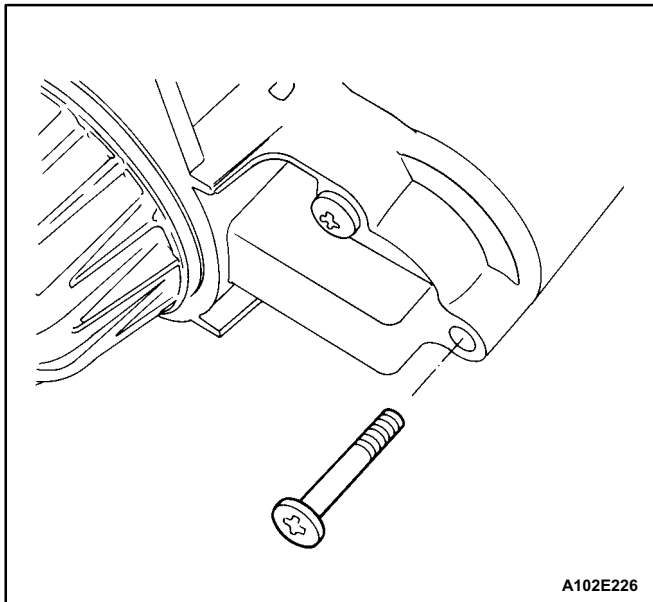

A102E226

12. Fasten the solenoid assembly with the screws.

Tighten

Tighten the starter solenoid assembly screws to 8 N•m (71 lb•in).

13. Install the field coil connection to the starter terminal. Install the nut.

Tighten

Tighten the starter field connector nut to 8 N•m (71 lb•in).

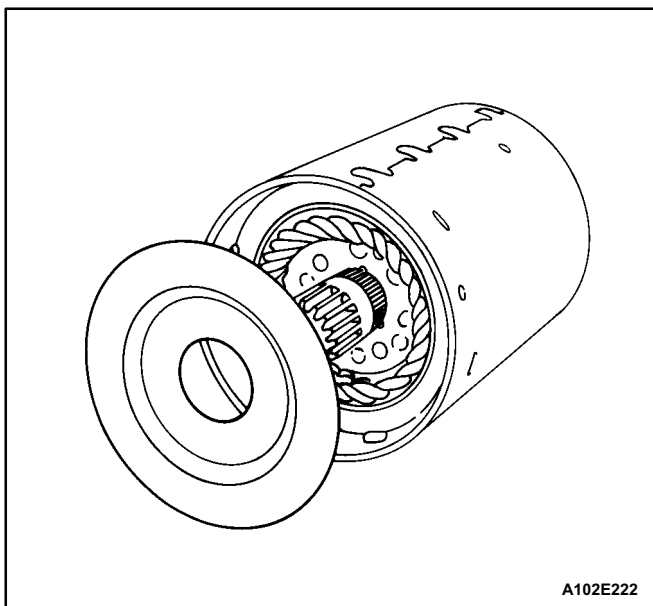

A102E222

14. Position the armature assembly into the field frame.

15. Place the shield on the armature and field frame assembly.

16. Install the armature and field frame assembly with the shield into the starter housing.

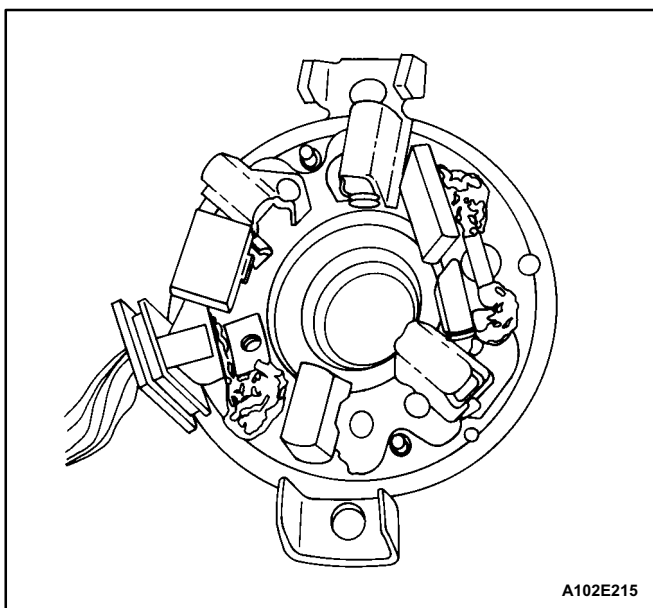

A102E215

17. Position the commutator end frame and brush holder assembly, lining up the end frame holes with the through-bolt holes in the housing.

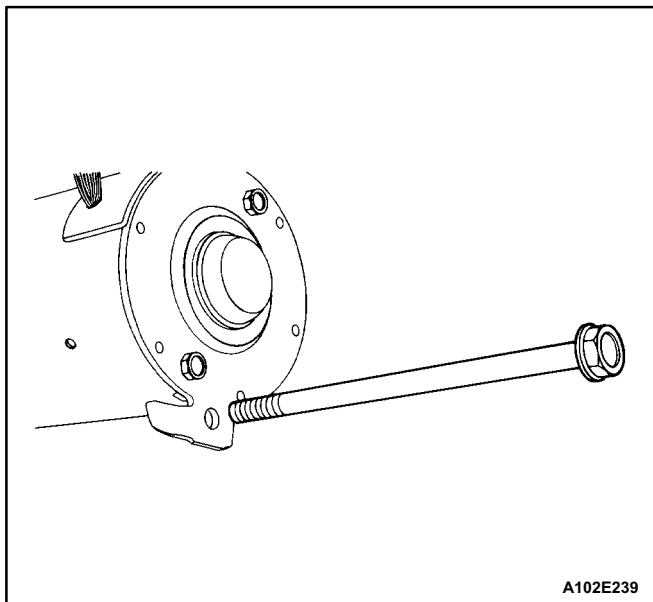

18. Install the starter through-bolts.

19. Install the starter. Refer to "Starter" in the On-Vehicle Service portion of this section.

Tighten

Tighten the starter through-bolts to 6 N•m (53 lb•in).

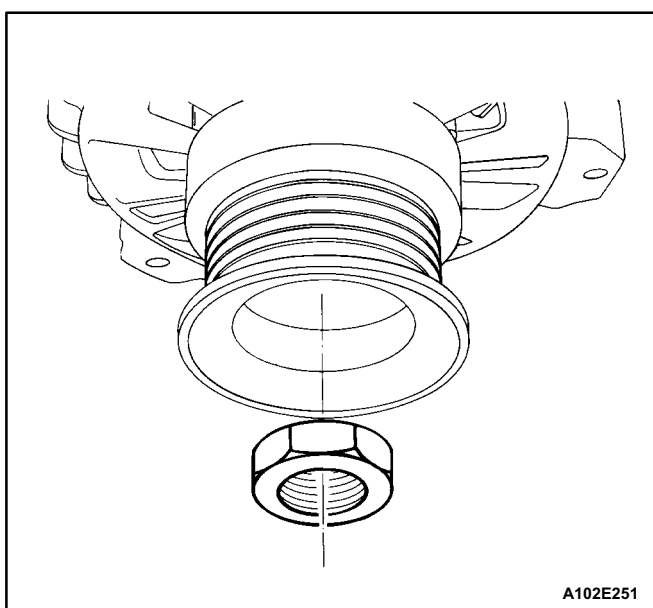

GENERATOR

Disassembly Procedure

1. Remove the generator. Refer to "Generator" in this section.
2. Remove the drive shaft nut.

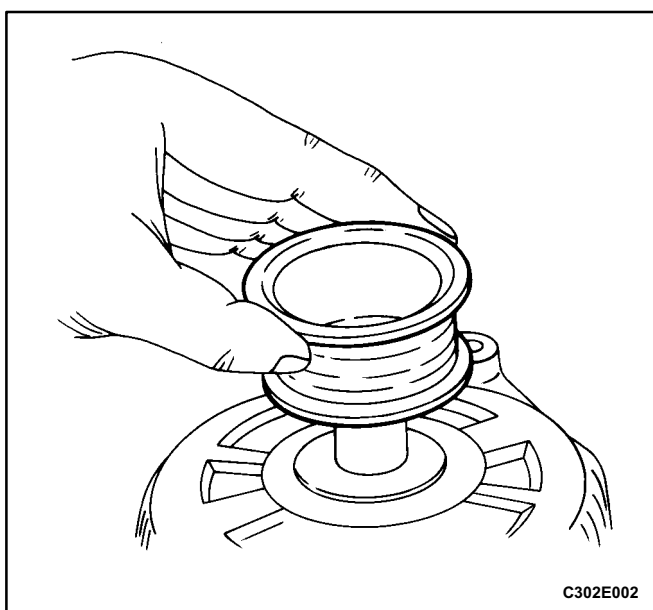

3. Remove the pulley and the collar from the drive shaft.

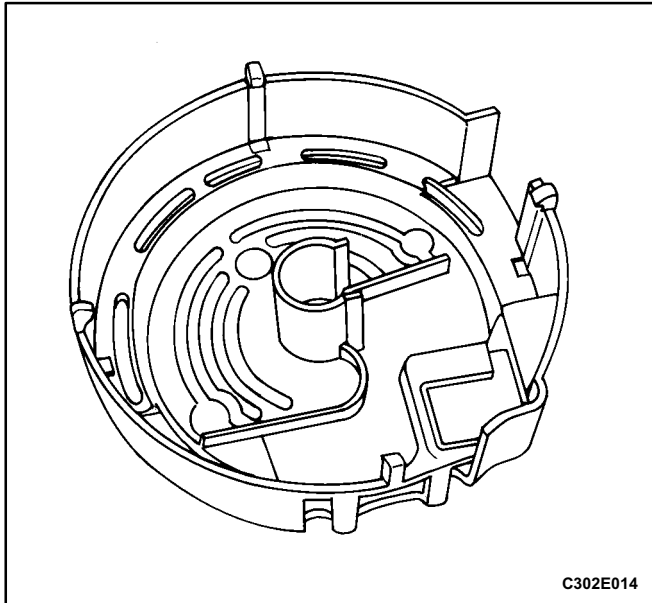

4. Pry off the plastic cover that encloses the rectifier and the regulator/brush holder assemblies. Inspect the cover for damage.

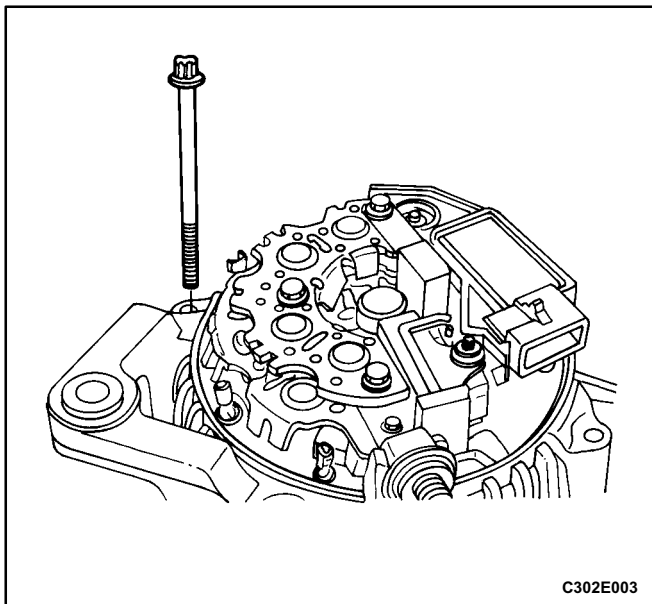

5. Remove the generator through-bolts.

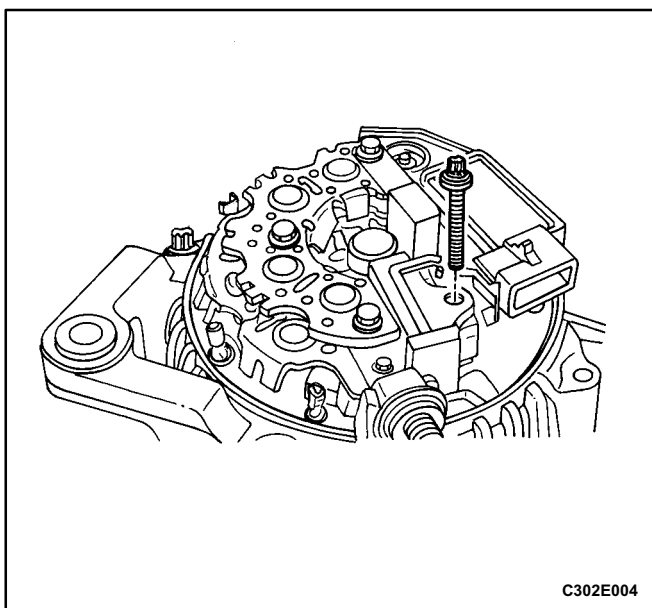

6. Remove the bolts that fasten the rectifier assembly and the regulator/brush holder assembly to the slip ring end frame.

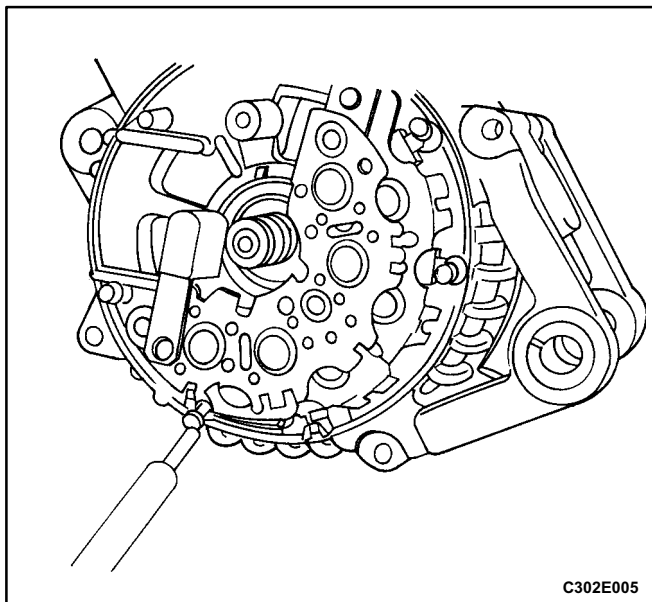

C302E005

7. To remove the regulator/brush holder and the rectifier assemblies, first melt the solder of the lead connecting the regulator/brush holder assembly to the rectifier assembly lead to the stator. Do the same to the other rectifier assembly leads to the stator (as shown).

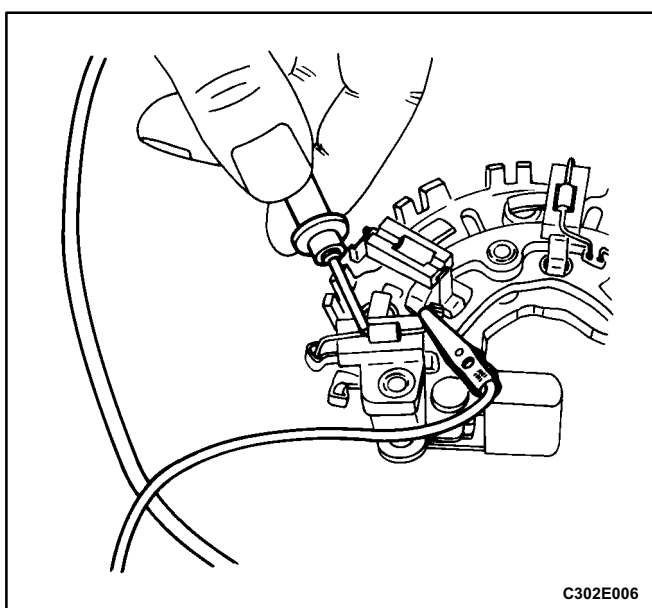

C302E006

8. Test each of the three diodes of the rectifier assembly for continuity. Connect the ohmmeter probes on each side of the diode. Retest by connecting the ohmmeter probes reversely. If the readings are the same, replace the rectifier.

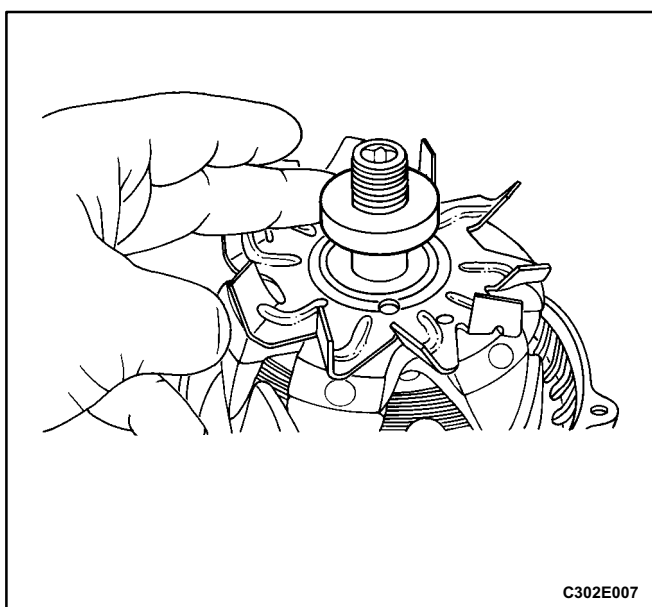

C302E007

9. Mark a line perpendicular to the crack between the case of the drive end frame and that of the slip ring end frame.
10. Pry open the drive end frame from the slip ring end frame.
11. Remove the collar.

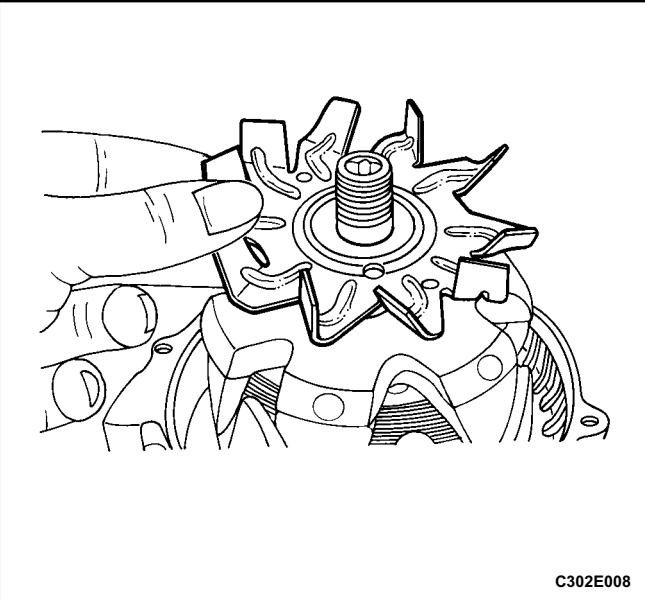

12. Remove the fan.

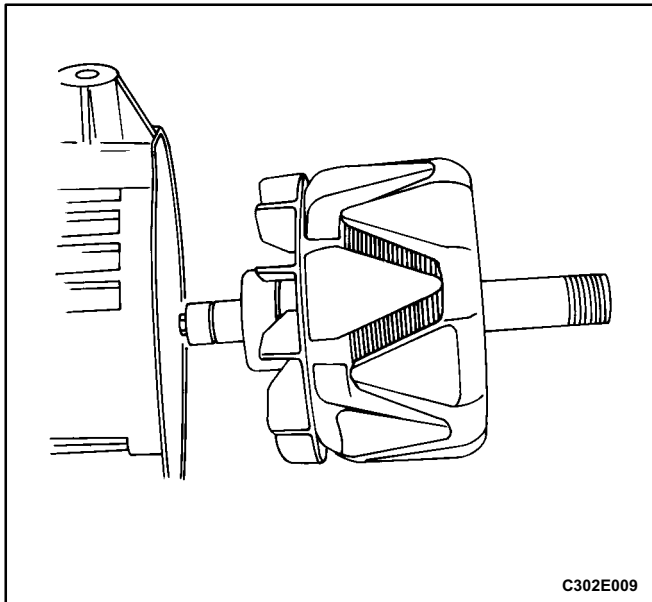

13. Separate the rotor from the slip ring end frame.

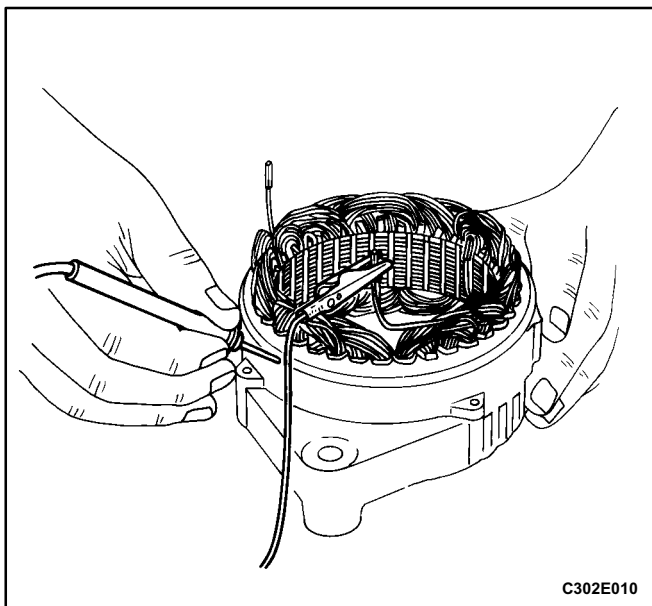

14. Using an ohmmeter, test the stator for ground. If the reading is low, replace the stator. Also check the stator for an open circuit by placing the probes on two terminals. If the reading is high (infinite), replace the stator.

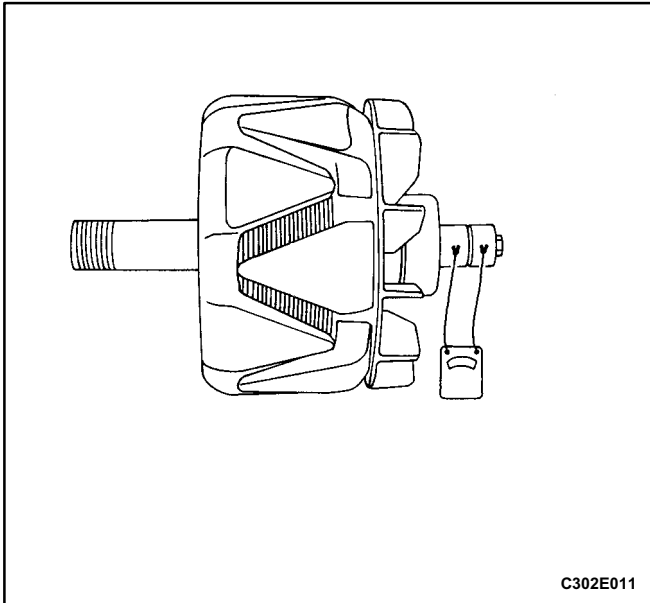

15. Using an ohmmeter, test the rotor for an open circuit. Check that there is continuity between the slip rings. Standard resistance (cold) is 2.8 to 3.0 ohms. If there is no continuity, replace the rotor.

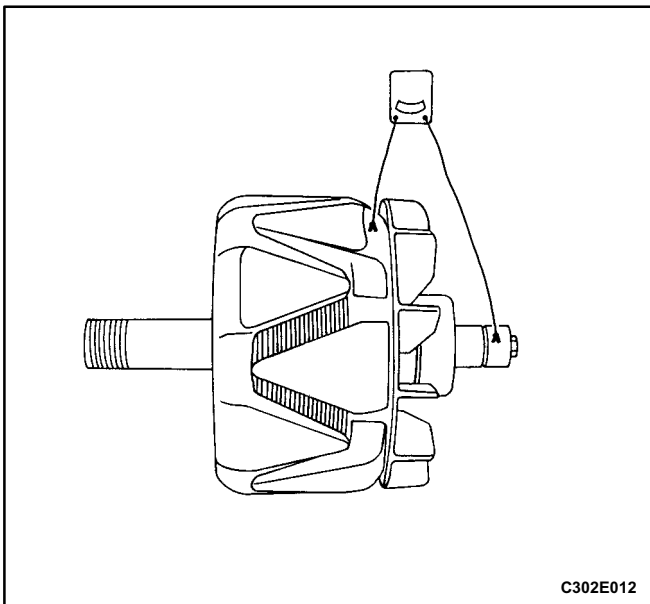

16. Using an ohmmeter, inspect the rotor for ground. Check that there is no continuity between the rotor and the slip ring.

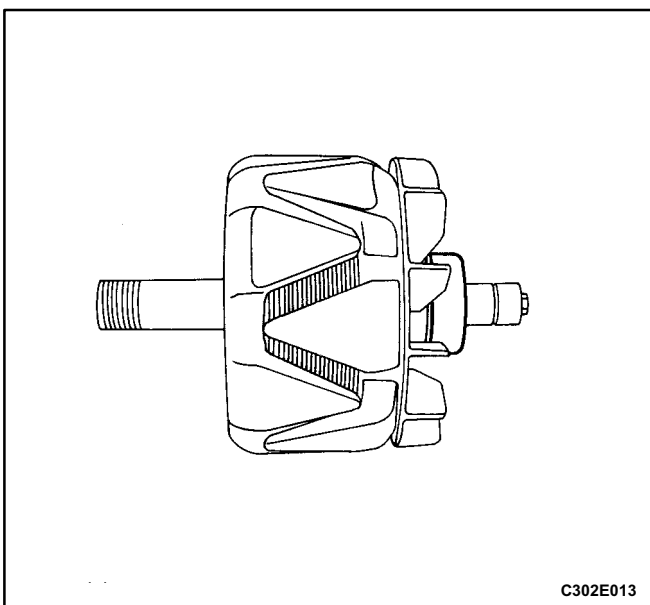

Assembly Procedure

1. Check the bearing on the fan side of the rotor assembly. Replace the bearing if it is rough or worn, and especially if the generator was diagnosed as having a noisy bearing with the vehicle running.
2. If required, install a new bearing and insert the bearing retainer on the rotor assembly shaft.

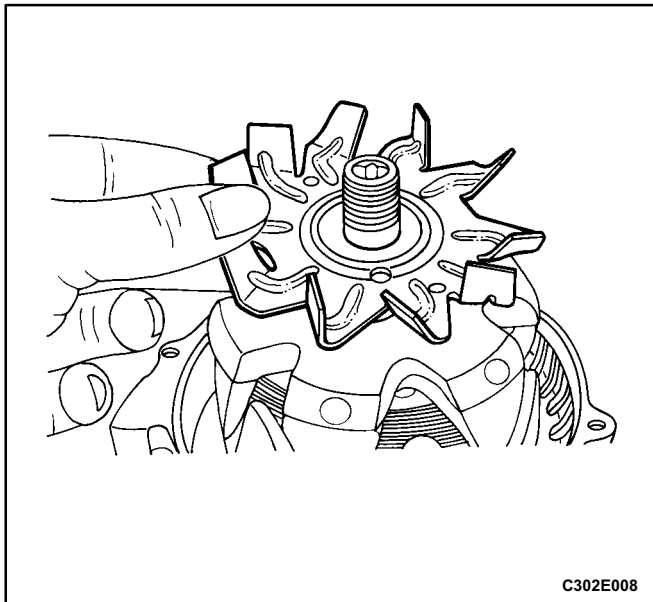

3. Press on rotor assembly into the end frame.
4. Install the fan on the rotor shaft.

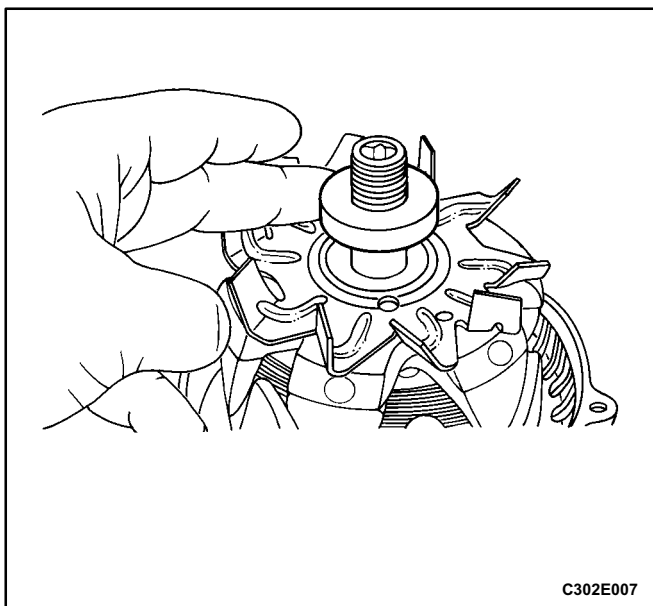

5. Install the collar.

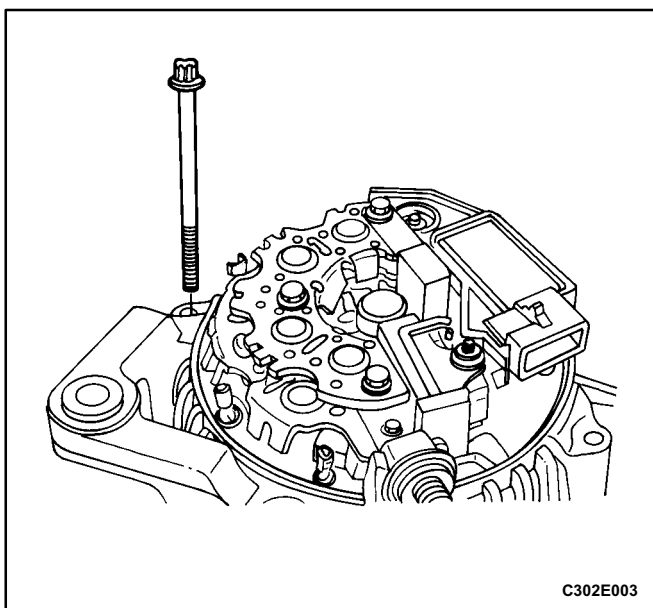

6. Install the slip ring end frame assembly by lining up the terminal ends of the stator with the end frame cover holes and then lining up the previously made marks on the drive end frame case and the slip ring end frame case before the two cases were separated.
7. Install the generator through-bolts.

Tighten

Tighten the generator through-bolts to 25 N•m (18 lb•ft).

C302E003

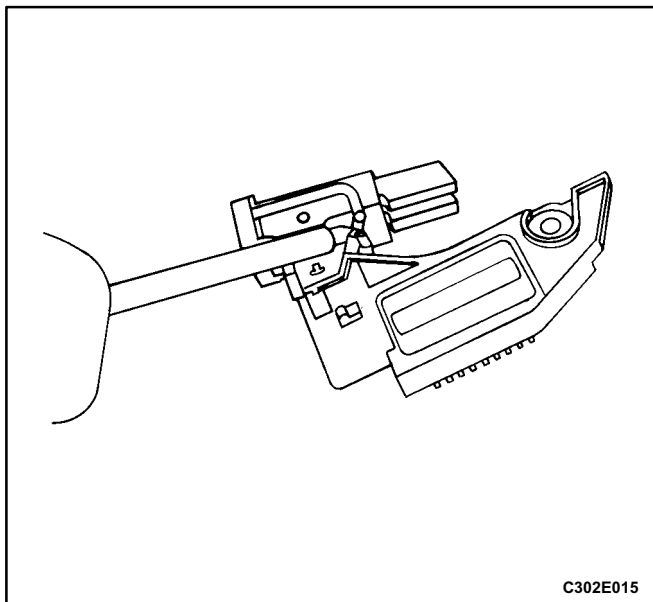

C302E015

8. Install the rectifier assembly by first soldering its terminals to the stator terminal ends.
9. If the brushes are worn, solder the terminal of the new brush holder assembly to the regulator assembly.

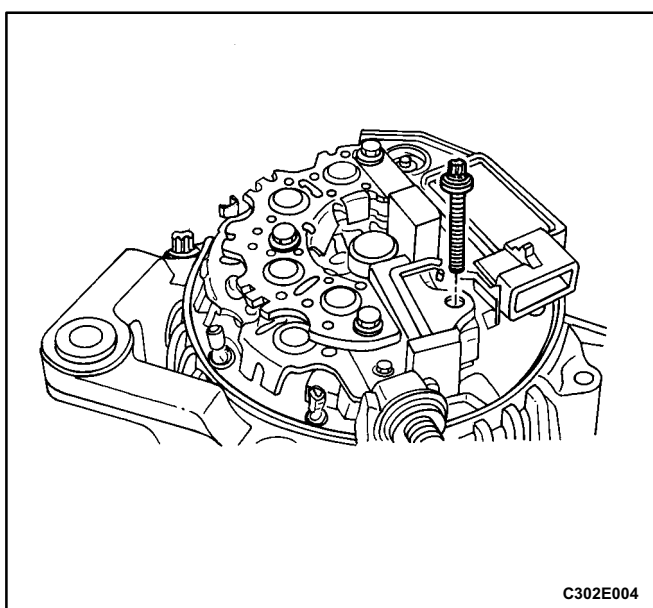

C302E004

10. Solder the terminal of the regulator/brush holder assembly to the rectifier assembly and fasten the rectifier and the regulator/brush holder assemblies to the slip ring end frame with the bolts.
11. Tighten the rectifier and regulator/brush holder assembly bolts until they are touching their respective mounting plates, and tighten the bolts with an additional quarter turn.

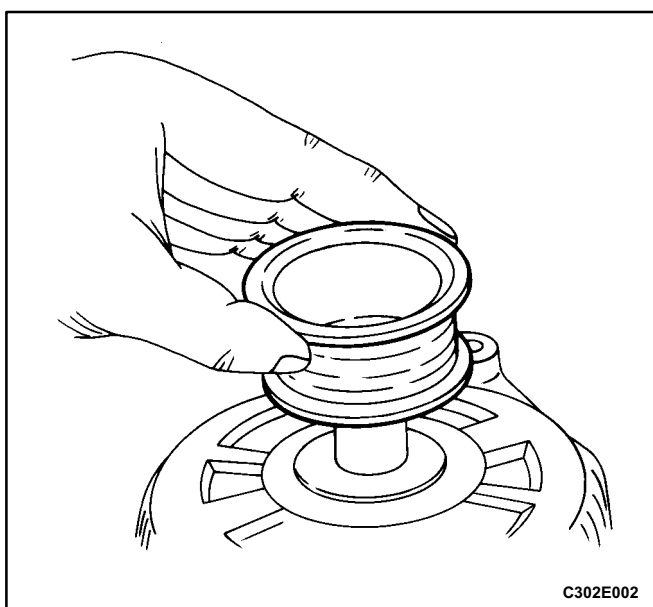

C302E002

12. Snap on the cover.
13. Install the collar and pulley on the drive end shaft.

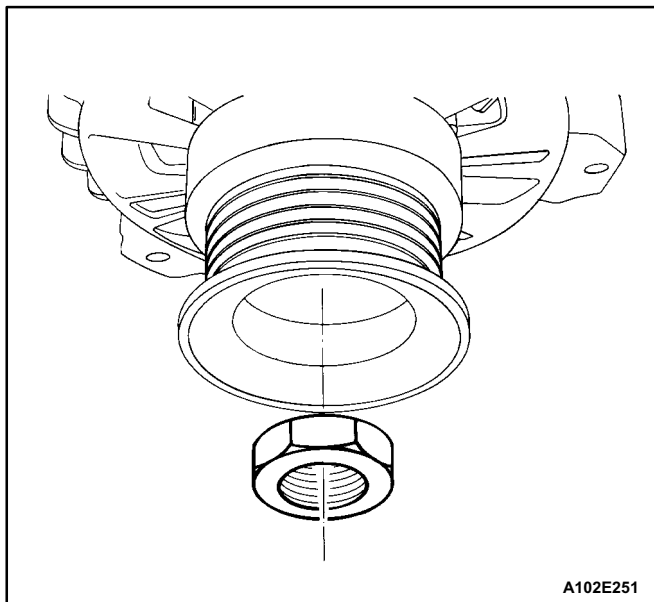

14. Install the drive shaft nut.

Tighten

Tighten the drive shaft nut to 100 N•m (74 lb•ft).

15. Install the generator. Refer to "Generator" in this section.

GENERAL DESCRIPTION AND SYSTEM OPERATION

BATTERY

The sealed battery is standard on all cars. There are no vent plugs in the cover. The battery is completely sealed, except for two small vent holes in the sides. These vent holes allow the small amount of gas produced in the battery to escape. The battery has the following advantages over conventional batteries:

- No water addition for the life of the battery.
- Overcharge protection. If too much voltage is applied to the battery, it will not accept as much current as a conventional battery. In a conventional battery, the excess voltage will still try to charge the battery, leading to gassing, which causes liquid loss.
- Not as liable to self-discharge as a conventional battery. This is particularly important when a battery is left standing for long periods of time.
- More power available in a lighter, smaller case.

The battery has three major functions in the electrical system. First, the battery provides a source of energy for cranking the engine. Second, the battery acts as a voltage stabilizer for the electrical system. Finally, the battery can, for a limited time, provide energy when the electrical demand exceeds the output of the generator.

RATINGS

A battery has two ratings: (1) a reserve capacity rating designated at 27°C (80°F), which is the time a fully charged battery will provide 25 amperes of current flow at or above 10.5 volts; (2) a cold cranking amp rating determined under testing at 18°C (0°F), which indicates the cranking load capacity.

RESERVE CAPACITY

The reserve capacity (RC) is the maximum length of time it is possible to travel at night with the minimum electrical load and no generator output. Expressed in minutes, the RC rating is the time required for a fully charged battery, at a temperature of 27°C (80°F) and being discharged at a current of 25 amperes, to reach a terminal voltage of 10.5 volts.

COLD CRANKING AMPERAGE

The cold cranking amperage test is expressed at a battery temperature of 18°C (0°F). The current rating is the minimum amperage, which must be maintained by the battery for 30 seconds at the specified temperature, while meeting a minimum voltage requirement of 7.2 volts. This rating is a measure of cold cranking capacity.

The battery is not designed to last indefinitely. However, with proper care, the battery will provide many years of service.

If the battery tests well, but fails to perform satisfactorily in service for no apparent reason, the following factors may point to the cause of the trouble:

- Vehicle accessories are left on overnight.
- Slow average driving speeds are used for short periods.
- The vehicle's electrical load is more than the generator output, particularly with the addition of aftermarket equipment.
- Defects in the charging system, such as electrical shorts, a slipping generator belt, a faulty generator, or a faulty voltage regulator.
- Battery abuse, including failure to keep the battery cable terminals clean and tight, or a loose battery hold-down clamp.
- Mechanical problems in the electrical system, such as shorted or pinched wires.

BUILT IN HYDROMETER

The sealed battery has a built-in, temperature compensated hydrometer in the top of the battery. This hydrometer is to be used with the following diagnostic procedure:

1. When observing the hydrometer, make sure that the battery has a clean top.
2. Under normal operation, two indications can be observed:
 - GREEN DOT VISIBLE - Any green appearance is interpreted as a "green dot," meaning the battery is ready for testing.
 - DARK GREEN DOT IS NOT VISIBLE - If there is a cranking complaint, the battery should be tested. The charging and electrical systems should also be checked at this time.
3. Occasionally, a third condition may appear:
 - CLEAR OR BRIGHT YELLOW - This means the fluid level is below the bottom of the hydrometer. This may have been caused by excessive or prolonged charging, a broken case, excessive tipping, or normal battery wear. Finding a battery in this condition may indicate high charging by a faulty charging system. Therefore, the charging and the electrical systems may need to be checked if a cranking complaint exists. If the cranking complaint is caused by the battery, replace the battery.

CHARGING PROCEDURE

1. Batteries with the green dot showing do not require charging unless they have just been discharged, such as in cranking a vehicle.
2. When charging sealed-terminal batteries out of the vehicle, install the adapter kit. Make sure all the charger connections are clean and tight. For best results, batteries should be charged while the electrolyte and the plates are at room temperature. A battery that is extremely cold may not accept current for several hours after starting the charger.
3. Charge the battery until the green dot appears. The battery should be checked every half-hour while

charging. Tipping or shaking the battery may be necessary to make the green dot appear.

- After charging, the battery should be load tested. Refer to "Starter Motor" in this section.

CHARGING TIME REQUIRED

The time required to charge a battery will vary depending upon the following factors:

- Size of Battery** - A completely discharged large heavy-duty battery requires more than twice the recharging time as a completely discharged small passenger car battery.
- Temperature** - A longer time will be needed to charge any battery at 18°C (0°F) than at 27°C (80°F). When a fast charger is connected to a cold battery, the current accepted by the battery will be very low at first. The battery will accept a higher current rate as the battery warms.
- Charger Capacity** - A charger which can supply only 5 amperes will require a much longer charging period than a charger that can supply 30 amperes or more.
- State of Charge** - A completely discharged battery requires more than twice as much charge as a one-half charged battery. Because the electrolyte is nearly pure water and a poor conductor in a completely discharged battery, the current accepted by the battery is very low at first. Later, as the charging current causes the electrolyte acid content to increase, the charging current will likewise increase.

CHARGING A COMPLETELY DISCHARGED BATTERY (OFF THE VEHICLE)

Unless this procedure is properly followed, a perfectly good battery may be needlessly replaced.

The following procedure should be used to recharge a completely discharged battery:

- Measure the voltage at the battery terminals with an accurate voltmeter. If the reading is below 10 volts, the charge current will be very low, and it could take some time before the battery accepts the current in excess of a few milliamperes. Refer to "Charging Time Required" in this section, which focuses on the factors affecting both the charging time required. Such low current may not be detectable on ammeters available in the field.
- Set the battery charger on the high setting.

Important: Some chargers feature polarity protection circuitry, which prevents charging unless the charger leads are correctly connected to the battery terminals. A completely discharged battery may not have enough voltage to activate this circuitry, even though the leads are connected properly, making it appear that the battery will not accept charging current. Therefore, follow the specific charger manufacturer's instruction for bypassing or overriding the circuitry so that the charger will turn on and charge a low-voltage battery.

- Continue to charge the battery until the charge current is measurable. Battery chargers vary in the amount of voltage and current provided. The time required for the battery to accept a measurable charger current at various voltages may be as follows:

Voltage	Hours
16.0 or more	Up to 4 hours
14.0-15.9	Up to 8 hours
13.9 or less	Up to 16 hours

- If the charge current is not measurable at the end of the above charging times, the battery should be replaced.
- If the charge current is measurable during the charging time, the battery is good, and charging should be completed in the normal manner.

Important: It is important to remember that a completely discharged battery must be recharged for a sufficient number of ampere hours (AH) to restore the battery to a usable state. As a general rule, using the reserve capacity rating (RC) as the number of ampere hours of charge usually brings the green dot into view.

- If the charge current is still not measurable after using the charging time calculated by the above method, the battery should be replaced.

JUMP STARTING PROCEDURE

- Position the vehicle with the charged battery so that the jumper cables will reach from the charged battery to the battery that requires charging.
- Turn off the ignition, all the lights, and all the electrical loads in both vehicles.
- Leave the hazard flasher on if jump starting where there may be other traffic and any other lights needed for the work area.
- Apply the parking brake firmly in both vehicles.

Notice: In order to avoid damaging the vehicle make sure the cables are not on or near pulleys, fans, or other parts that will move when the engine starts.

- Shift an automatic transmission to PARK, or a manual transmission to NEUTRAL.

Caution: In order to avoid injury, do not use cables that have loose or missing insulation.

- Clamp one end of the first jumper cable to the positive terminal on the booster battery. Make sure it does not touch any other metal parts.
- Clamp the other end of the same cable to the positive terminal on the discharged battery. Never connect the other end to the negative terminal of the discharged battery.

Caution: Do not attach the cable directly to the negative terminal of the discharged battery. Doing so could cause sparks and possible battery explosion.

8. Clamp one end of the second cable to the negative terminal of the booster battery.
9. Make the final connection to a solid engine ground, such as the engine lift bracket at least 450 millimeters (18 inches) from the discharged battery.
10. Start the engine of the vehicle with the good battery. Run the engine at a moderate speed for several minutes.
11. Then start the engine of the vehicle with the discharged battery.
12. Remove the jumper cables by reversing the above sequence exactly, removing the negative cable from the vehicle with the discharged battery first. While removing each clamp, take care that it does not touch any other metal while the other end remains attached.

GENERATOR

The DelcoRemy CS charging system has several models available, including the CS-128D. The number denotes the outer diameter in millimeters of the stator lamination.

CS generators are equipped with internal regulators.

Unlike three-wire generators, the CS-128D may be used with only two connections: battery positive and an "L" terminal to the charge indicator lamp.

As with other charging systems, the charge indicator lamp lights when the ignition switch is turned to RUN, and goes out when the engine is running. If the charge indicator is on with the engine running, a charging system defect is indicated. This indicator light will glow at full brilliance for several kinds of defects as well as when the system voltage is too high or too low.

The regulator voltage setting varies with temperature and limits the system voltage by controlling rotor field current. Achieve correct average field current for proper system voltage control by varying the on-off time. At high speeds, the on-time may be 10 percent and the off-time 90 percent. At low speeds, with high electrical loads, the on-time may be 90 percent and the off-time 10 percent.

CHARGING SYSTEM

CS generators use a new type of regulator that incorporates a diode trio. A Delta stator, a rectifier bridge, and a rotor with slip rings and brushes are electrically similar to earlier generators. A conventional pulley and fan are used. There is no test hole.

STARTER

Wound field starter motors have pole pieces, arranged around the armature, which are energized by wound field coils.

Enclosed shift lever cranking motors have the shift lever mechanism and the solenoid plunger enclosed in the drive housing, protecting them from exposure to dirt, icy conditions, and splashes.

In the basic circuit, solenoid windings are energized when the switch is closed. The resulting plunger and shift lever movement causes the pinion to engage the engine flywheel ring gear. The solenoid main contacts close. Cranking then takes place.

When the engine starts, pinion overrun protects the armature from excessive speed until the switch is opened, at which time the return spring causes the pinion to disengage. To prevent excessive overrun, the switch should be released immediately after the engine starts.

STARTING SYSTEM

The engine electrical system includes the battery, the ignition, the starter, the generator, and all the related wiring. Diagnostic tables will aid in troubleshooting system faults. When a fault is traced to a particular component, refer to that component section of the service manual.

The starting system circuit consists of the battery, the starter motor, the ignition switch, and all the related electrical wiring. All of these components are connected electrically.